

A silver car is positioned on a lift in a garage. The lift's vertical post has the word 'CLAS' written on it. The background features a road curving through a forest with vibrant autumn foliage in shades of orange, red, and yellow. The overall scene is a composite image.

CLAS[®]

From October 1st to
December 31st 2024

Selection
FALL
2024

MOBILE SCISSOR LIFT DUAL CYLINDER LOW RAISE 230V 3T

PE 6102M

Especially adapted to painting, bodywork and brake and tyre service activities.
Easy access: 115mm lowered floor clearance, lockable access ramps to extend platforms.
Working comfort: easy to move thanks to removable wheels and traction handle.
Easy storage of components on the console.

2999 €VAT Excl.

Instead of
3199 €VAT Excl.*



EXCLUDING TRANSPORT COST

NEW



Electric rack locking,
no pneumatic power
supply required



+ Supplied with
mobility kit
100% electric

115mm
Extra flat



Safety punch
stop



Easy storage of
components on the control
panel

Specifications:

- lifting height: 115-1000mm
- lifting time: +/- 50s
- lowering time: +/- 30s
- track width/length: 460/1410-2010mm
- control console
- drive power: 3kW
- drive voltage: (3 -) 400/50 V/Hz
- emergency lowering system in case of power failure
- intermediate stop 20 cm above ground for operator safety and anti-crushing audible signal
- engine protection
- rack and pinion safety
- electric lock release (no pneumatic power supply required)

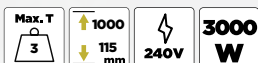

3T



DOUBLE SCISSOR LIFT 400V 3.6T LOW PROFILE ON/IN-GROUND

PE 6236T

Especially adapted to painting, bodywork and brake and tyre service activities.

Installation possibilities: in or on ground.

Easy access: 110mm lowered floor clearance, lockable access ramps to extend platforms.

Maximum comfort and safety: double hydraulic master-slave safety system, combined with a rack and pinion system, to maintain the lift in position for long periods.

5499 €VAT Excl.

Instead of
5799 €VAT Excl.*



EXCLUDING TRANSPORT COST

NEW

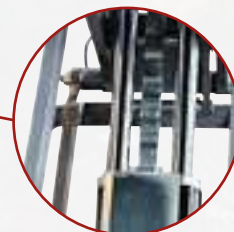
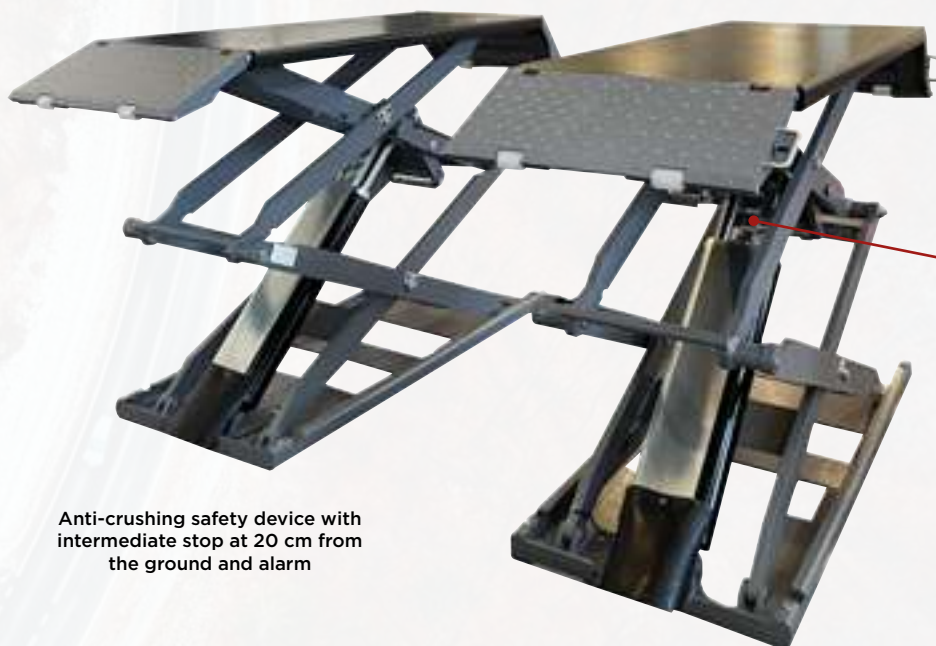

Rack and pinion safety

Anti-crushing safety device with intermediate stop at 20 cm from the ground and alarm



For free-standing or built-in use

110mm
Extra flat

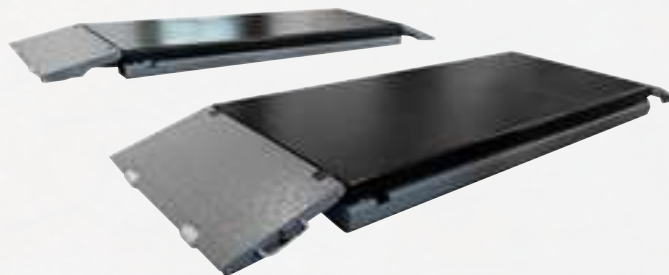

Specifications:

- lifting height: 110-1880mm
- lifting time: +/- 50s
- lowering time: +/- 30s
- track width/length: 630/1480-2090mm
- system synchronization: photo cell
- air supply required 6-8 bar.
- control console
- drive power: 3kw
- drive voltage: (3 -) 400V/50 V/Hz
- emergency lowering system in case of power failure
- intermediate stop at 20 cm from the ground for operator safety and anti-crushing audible signal

Max. T 3.6	1880 110 mm	400V	3000 W
---------------	----------------	------	-----------

3.6T



2 COLUMNS ASYMETRIC POST LIFT WITH BASEMENT 400V 4T 2ARMS 1.10+1.50m

PE 2100T

Accessory of PE 2106T

Post lift designed to facilitate column installation and alignment thanks to its 40mm-thick base.

With the PE 2101 option, it can be used for screeds that don't meet the minimum thickness requirement of 200mm (it can cover up to 150mm), or that present a slight flatness problem.

Electro-hydraulic post lift.

Pusher cylinder on cable, cart traction by chain.

Multiple lifting capacities thanks to telescopic arms in asymmetrical version with 1100 mm and 1500 mm 3-stage arms.

3799 €VAT Excl.
Instead of 3999 €VAT Excl.*



EXCLUDING TRANSPORT COST

NEW

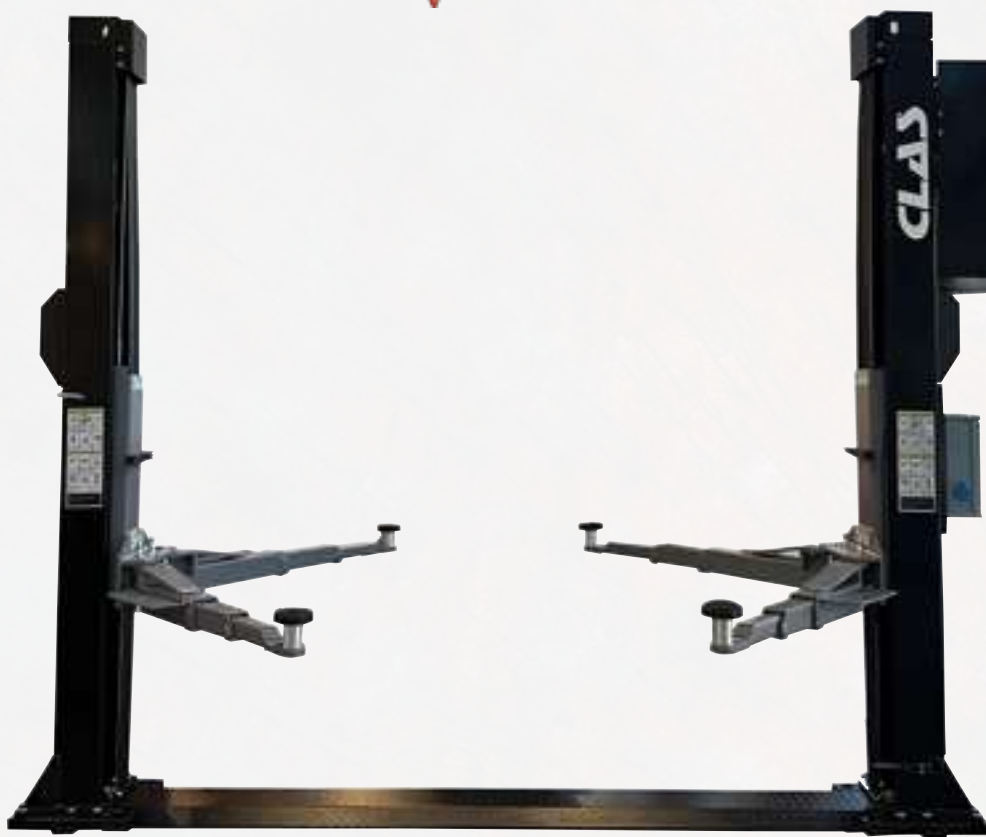

Specifications:

- lifting height: 100-2100mm
- lifting time: +/- 50s
- lowering time: +/- 30s
- drive power: 2.2kW
- drive voltage: 400V/50 V/Hz
- adjustable screw buffers, stroke 70-140mm
- automatic release of safety catches
- emergency lowering system in the event of power failure
- system synchronization: by cable
- intermediate stop 20 cm above ground for user safety and anti-crushing audible signal
- engine protection
- door protection on columns
- 230V electrical socket on electrical box
- protective strip for cylinder, chain and cables included on each column
- supplied with 4x70mm risers and brackets
- Epoxy paint

+ Low thickness slab



4T



2-speed automatic tire changer with mounting aid (assistance arm)
Automatic tire changer specially adapted for the effortless mounting and dismounting of all car, utility and 4x4 tires.
Equipped with the articulated bead pusher device and arm.

1 SPEED 230V

AUTOMATIC TIRE CHANGER 10"-24" 1 SPEED SYSTEM 230V

DM 1522



Specifications:

- horizontal arm on roller for easy movement
- inflator with pressure gauge
- maximum tire diameter: 1180mm
- max. tire width: 3 to 12 inches
- arched platform with anti-pinch safety device
- outside rim diameter: 10 to 21 inches
- inner rim diameter: 12 to 24 inches
- 1 speed without switch: rotation speed 1: 6.5 rpm
- ergonomic, intuitive pedals
- 2-position adjustable bead breaker shovel and double-acting cylinder
- operating pressure: 8-10bar
- air cleaner and oil lubricator
- tubeless inflation safety valve: 3.5bar
- noise < 70dB
- power supply: 230V
- power: 0.75kW
- bead breaker power: 2500kg
- tire changer weight: 315kg
- dimensions: 1850x1800x1980mm



4299 €VAT Excl.*

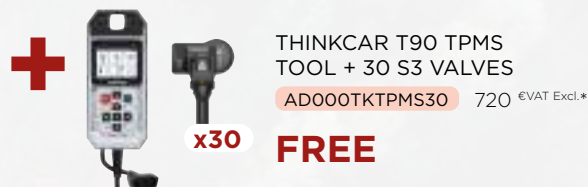

2 SPEED 400V

AUTOMATIC TIRE CHANGER 10"-24" 2 SPEED SYSTEM 400V

DM 1501



Specifications:

- horizontal arm on roller for easy movement
- inflator with pressure gauge
- maximum tire diameter: 1180mm
- max. tire width: 3 to 12 inches
- arched platform with anti-pinch safety device
- outside rim diameter: 10 to 21 inches
- inner rim diameter: 12 to 24 inches
- 2 speeds without switch: rotation speed 1: 6.5 rpm rotation speed 2: 13rpm
- ergonomic, intuitive pedals
- 2-position adjustable bead breaker scoop and double-acting cylinder
- operating pressure: 8-10bar
- air cleaner and oil lubricator
- tubeless inflation safety valve: 3.5bar
- noise < 70dB
- power supply: 400V-50Hz
- power: 0.85-1.1kW
- bead breaker power: 2500kg
- dimensions: 1900x1580x2000mm



4190 €VAT Excl.*



TIRE CHANGER WITH LEVERLESS 13-28" 2 SPEED SYSTEM 400V

DM 1900

2-speed automatic tire changer with mounting aid (assist arm) + pneumatic assistance on leverless stem.

Automatic tire changer specially designed for effortless mounting and demounting of all passenger car, commercial vehicle and 4x4 tires.

Equipped with articulated bead lift and push device.

4990 €VAT Excl.*



x30

THINKCAR T90 TPMS TOOL + 30 S3 VALVES

AD000TKTPMS30 720 €VAT Excl.*

FREE

+ No effort, no use of exercise levers



Specifications:

- horizontal arm moving on roller for easy translation
- jib equipped with leverless pneumatic finger
- inflator with pressure gauge
- maximum tire diameter: 1100mm
- max. tire width: 3 to 14 inches
- curved platform with anti-pinch safety device
- outer rim diameter: 13 to 24 inches
- inner rim diameter: 15 to 28 inches
- 2 speeds without switch :
rotation speed 1: 6.5 rpm
rotation speed 2: 13rpm
- ergonomic, intuitive pedals
- 2-position telescopic and swiveling take-off shovel with double-acting cylinder
- operating pressure: 8-10bar
- air cleaner and oil lubricator
- tubeless inflation safety valve: 3.5bar
- noise level < 70dB
- power supply: 400V-50Hz
- power: 0.85-1.1kW
- detent power: 2800kg
- dimensions: 1900x1580x2000mm



WHEEL LIFTER FOR TIRE CHANGER

DM 0000

Accessory of DM 1501/DM 1522/DM 2000/DM 0500BL/DM 1900/DM 0600BL

This tool, which works with most of the tire changers of the market, will allow you to work quickly and without any extra effort.

Thanks to its pneumatic foot-operated control, you can lift and rotate the wheel horizontally to position it on the tire changer table. Therefore, the operation of positioning the wheel on the table will be done easily with a minimum of physical effort, thereby limiting the risk of MSD (musculoskeletal disorders).

+ Ergonomic Limits the risk of MSD



579 €VAT Excl.*

Instead of 679 €VAT Excl.*



TN

ROLL PLATFORM FOR BEAD BREAKER

DM 0200

Accessory of DM 2000/DM 1000/DM 1500/DM 0500BL/DM 0550BL/DM 1050/DM 1020/DM 1250/DM 1520/DM 1501/DM 1521/DM 0500BLP/DM 2000P/DM 0600BL/DM 1900

+ Workshop ergonomics increased



149 €VAT Excl. **←←←**
Instead of 169 €VAT Excl.*

Max. Kg
70

2
WARRANTY

TN

○ WHITE TIRE MOUNTING PASTE 5KG

DM 1320

Spare part of DM 0600BL/DM 1501/DM 1522/DM 1900

13,90 €VAT Excl. **←←←**
Instead of 15,90 €VAT Excl.*



+ Does not freeze (in the pot)

NEW

● BLACK TIRE MOUNTING PASTE 5KG

DM 1330

Spare part of DM 0600BL/DM 1501/DM 1522/DM 1900

14,90 €VAT Excl. **←←←**
Instead of 16,90 €VAT Excl.*

Specifications:

- ensures fast, precise centering of the tire on the rim thanks to its superior lubricity
- easy, precise brush application
- retains its lubricity even when open
- quick-drying to prevent rotation on the rim

- limits corrosion and tire sticking to the rim
- non-irritant (chemically neutral)
- flame-retardant
- does not damage rubber
- does not alter paintwork
- for all types of vehicle

NO
WARRANTY

TN

DISPLAY TIRES

EG 012

154 €VAT Excl. **←←←**
Instead of 190 €VAT Excl.*

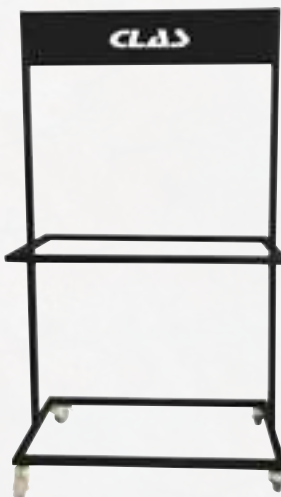

+ Up to 10 tires

Specifications:

- support for up to 10 tires
- metal
- 2 braked wheels
- level height 760mm
- interaxial 450mm
- dimensions: L.1060xW.510xH.1910mm

2
WARRANTY

MANUAL MOTORIZED WHEEL BALANCER LED SCREEN

EQ 0600BL

B.LINE
BUDGET SOLUTION

1599 €VAT Excl.*



CYLINDRICAL UNIVERSAL CENTERING PLATE Ø40mm

EQ 6400BL 489 €VAT Excl.*

FREE



Specifications:

- power supply: 230V-50Hz
- motor power: 180W
- dimensions open housing: 880x980x1420mm
- LED display
- maximum wheel weight: 65kg
- minimum rim diameter: 10 inches
- max rim diameter: 24 inches
- rim width: from 1 to 20 inches
- manual measurement of 3 parameters: offset-diameter-width
- safety housing
- rotation speed: 200 rpm
- compartmentalized tray for cones and weights
- 4 storage racks
- noise level <70dB
- weight: 87kg



MOTORIZED WHEEL BALANCER WITH DIGITAL DISPLAY

EQ 1000

2150 €VAT Excl.
Instead of 2190 €VAT Excl.*



CYLINDRICAL UNIVERSAL CENTERING PLATE Ø40mm

EQ 6400BL 489 €VAT Excl.*

FREE



Specifications:

- power supply voltage: 220V-50Hz
- dimensions (wheel guard opened): 1550x1160x1490mm
- sound level < 69dB
- digital display (automatic standby mode if the machine is not being in use after 5min)
- max. wheel diameter: 1100mm
- max. wheel weight: 70kg
- rim diameter: 1-28"
- rim width: 1.5-20"
- wheel 3 parameters manual measurement
- automatic wheel guard
- one balance time: 7s
- rotating speed: 140rpm
- shaft: L.210mm-Ø40mmx4mm
- ergonomic and functional weight holder top with large trays for different types of counterweights and tools.
- 4 storage media
- support of positioning weight
- weight: 149kg

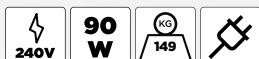

+ A wide range of programs



TE

AUTOMATIC WHEEL BALANCER 3D DIGITAL DISPLAY+LASER POINTER

EQ 2100

2850 €VAT Excl.

Instead of
2950 €VAT Excl.*



CYLINDRICAL UNIVERSAL
CENTERING PLATE
Ø40mm

EQ 6400BL 489 €VAT Excl.*

FREE

Specifications:

- power supply voltage: 220V-50Hz
- motor power: 90W
- dimensions (wheel guard opened): 1550x1160x1490mm
- sound level < 69dB
- digital display (automatic standby mode if the machine is not being used after 5min)
- max. wheel diameter: 1100mm
- max. wheel weight: 70kg
- max. rim diameter: 28»
- rim width: 1.5-20»
- automatically measures 3 parameters: protrusion, diameter, width
- laser pointer for mass positioning
- automatic wheel casing with automatic ignition
- duration of measurement cycle: 7s
- rotating speed: 140rpm
- shaft: L.210mm-Ø40mmx4mm
- ergonomic and functional weight holder top with large trays for different types of counterweights and cones.
- 4 storage media
- clip to position weights
- weight: 149kg



Laser pointer
Electromagnetic brake
Automatic ribbing



WHEEL LIFTER FOR WHEEL BALANCER

EQ 0000

Accessory of EQ 1000/EQ 2100/EQ 0500BL/EQ 0600BL

Facilitates the positioning of the wheel on the balancing shaft. The operator can effortlessly place the wheel to be balanced thanks to the universal pneumatic assistant (compatible with all types of balancing machines).
Reduced size, and pressure adjustment thanks to the regulator.



Ergonomic
Limits the risk of MSD



Specifications:

- lifting height : 320mm
- maximum lifting capacity : 80Kg
- platform width: 305mm
- dimensions: 950x660x940mm
- up-down speed: joystick-controlled



750 €VAT Excl.

Instead of 850 €VAT Excl.*



LCV CENTERING CONE Ø118- 174mm+SPACER DISK Ø40mm KIT

EQ 8093

Accessory of EQ 1000/EQ 2000/EQ 1050/
EQ 2100/EQ 0600BL



299 €VAT Excl.

Instead of 382 €VAT Excl.*



TN

ELECTRIC & RECHARGEABLE WHEEL LIFTER MAX. 60kg

OE 9000



+ Compatible with scissor lifts

2299 €VAT Excl.

Instead of 2499 €VAT Excl.*

Specifications:

- lifting capacity: 60kg
- wheels 135/80 R13 to 295/25 R22
- max height of the hub: 145cm
- up/down control integrated in the handle
- lifting speed: 0.14m/s
- lifting system-motorized screw
- 4 swiveling wheels for greater maneuverability
- anti-fall security feature
- emergency stop button
- reels to facilitate rotation to position the wheel on the hub
- LED indicators:
 - Battery charge level
 - Max. charge capacity exceeded
 - emergency stop function deployed
 - engine temperature of the upper screw
 - batteries 12V 12Ah
 - charger: 220V-AC
 - dimensions: L.725xW.800xH.1710mm



EURODAINU INFLATOR GUN
0.7-11BAR

TN

OP 0149

Specifications:

- dial: Ø80mm (graduated from 0.7 to 11bar)
- 1/4" threaded inlet
- filtered, non-lubricated air supply
- high-end thermoplastic components
- anti-pinch handle cataphoresis-treated to prevent corrosion
- elastomer protector enveloping measuring system
- stainless steel and nickel silver micro-porous filter to filter the air in the indicator mechanism.
- resistant to accidental overpressure of 13.75bar
- weight: 0.9 kg



99 €VAT Excl.*



IMPACT SOCKET 1/2" KIT
FOR ALU RIMS (4 PCS)

OM 7036 42 €VAT Excl.*

FREE



19I TIRE BEAD BLASTER CAR/
LCV/HGV

TN

OP 0659

Specifications:

- steel tank 19l
- barrel width: 80mm
- discharge: valve (1.5") 1/4 turn
- handle in upper position
- pressure gauge 0-16bar
- safety valve 6.0bar
- working pressure: 7.5bar
- weight: 12kg



229 €VAT Excl.

Instead of 249 €VAT Excl.*



12I ALUMINUM AIR BLASTER/BAZOOKA

TN

OP 0679

+ Light and ergonomics

329 €VAT Excl.

Instead of 349 €VAT Excl.*



Supplied with PU barrel and metal barrel

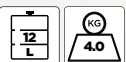

18I ALUMINUM AIR BLASTER/
BAZOOKA

TN

OP 0689

379 €VAT Excl.

Instead of 399 €VAT Excl.*



Specifications:

- 18L aluminium tank
- 1 PU nozzle, length 200mm, does not damage rims
- 1 metal nozzle, length 300mm
- barrel width: 250mm
- height: 680mm
- ergonomic 45° handle
- pressure gauge 0-16bar
- 10.0bar safety valve
- operating pressure: between 6 and 8 bar
- weight: 5.5kg

+ Lightweight and ergonomic



THINKCAR T-WAND 100 DIAGNOSTIC TOOL

AD000TKTT1

TPMS



NEW

+ Covers 98% of valves on the market!

Specifications:

- system: ARM
- cable: 1.2M
- working voltage: 9-18V
- current: ≤ 500mA
- updates: via SD card / PC
- battery: 3100mAh/3.7V
- 3.5" screen size

320 €VAT Excl.*

2
WARRANTY

VALVE TPMS VENU 5 PRO 315Mhz & 433Mhz

ADTK5PRO

NEW



+ Programmable up to 75cm
No need to be glued to the valve

Buy x1

23 €VAT Excl.*

Buy x12

22 €VAT Excl.*
Per unit
Instead of 23 €VAT Excl.*

Specifications:

- battery: 4-6 years
- frequency support: 315MHz / 433MHz
- adjustable installation angle: 15-30°
- certificates: CE, FCC, IC, ROHS, CP65
- pressure monitoring: 0-9Bar (0-900kpa)
- IP67 RATING
- net weight: 29g

2
WARRANTY

MUSHROOM PLUG TIRE REPAIR KIT 8mm WITH DRILL

EG 0265

This new solution for repairing tubeless tires consists of inserting a mushroom plug with vulcanizer without removing the tire.

Scan to watch the video



+ Intervention possible without removing the tire.

164 €VAT Excl.*



1/2» CROSS TORQUE WRENCH 70-170Nm 490mm + 3 SOCKETS

OM 0755 79 €VAT Excl.*

FREE

Contents:

- SA0260: insertion gun
- SA2608 x2: insertion nozzle Ø8mm
- SA2602: 1 preparation rasp
- SA2603: nozzle insertion tip
- SA0257 x2: 50 vulcanizing mushrooms Ø8mm
- SA0259: 1 bottle of vulcanizer 250ml
- SA1265: 6mm drill for tires

Options:

- SA0258: 20 mushrooms Ø11mm
- SA2601: insertion nozzle Ø11mm



TE



+ Mobile

AIR COMPRESSOR 100L 3HP

OP 3600

874 €VAT Excl.*



1/2» D. IMPACT
WRENCH 1600Nm
DOUBLE HAMMER

OP 1522BL 75 €VAT Excl.*

FREE

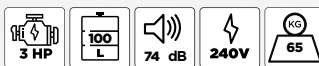

AIR COMPRESSOR 200L 3HP

OP 3602

1165 €VAT Excl.*

+ FREE



1/2» D. IMPACT
WRENCH 1600Nm
DOUBLE HAMMER

OP 1522BL 75 €VAT Excl.*



AIR REEL
Ø8mm 10m

OP 0083BL 79 €VAT Excl.*

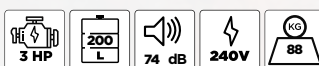

2
WARRANTY

Specifications:

- belt drive
- volume generated: 320 l/min
- 1500 rpm
- max pressure: 10bar
- engine power: 3cv-2.2kW
- twin-cylinder
- electrical supply: mono 230V
- equipped with regulator
- visible oil level

ALUMINUM AIR PIPE AND FITTING KIT Ø16mm L.20m 3 DOWNPIPES

KR 2016

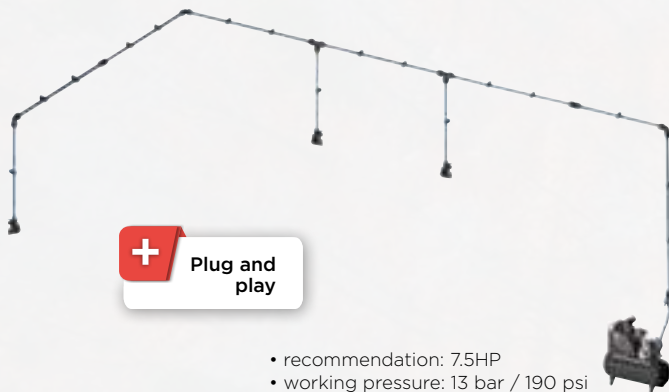

+ Plug and play

- recommendation: 7.5HP
- working pressure: 13 bar / 190 psi

20 m

892 €VAT Excl.*

Instead of 925 €VAT Excl.*

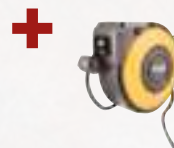

AIR REEL
Ø8mm 10m

OP 0083BL 79 €VAT Excl.*

FREE

5
WARRANTY

ALUMINUM AIR PIPE AND FITTING KIT Ø25mm L.36m 5 DOWNPIPES

KR 4425



+ Plug and play

Recommendation: 10HP
and more compressor

36 m

1900 €VAT Excl.*

Instead of 1995 €VAT Excl.*

+ FREE



AIR REEL
Ø8mm 10m

OP 0083BL 79 €VAT Excl.*



1/2» D. IMPACT
WRENCH 1600Nm
DOUBLE HAMMER

OP 1522BL 75 €VAT Excl.*

5
WARRANTY

This extractor is the easiest installation kit to install on a wall or on the front. The equipment allows to work in a healthy environment without inhalation of exhaust gases and in compliance with the safety standards at work.



+ Easy to install

SINGLE EXTRACTOR GROUP 5m Ø100mm 230v

AG 0019

1699 €VAT Excl.

Instead of 1799 €VAT Excl.*



SINGLE EXTRACTOR GROUP 5m Ø100mm 400V

AG 0020

1550 €VAT Excl.

Instead of 1620 €VAT Excl.*



Specifications:

- painted steel structure ral 7040
- Ø100mm hose (-40° to +200°) in high-temperature EPDM vulcanized fabric. hose structure is completely anti-crushing, maintains flexibility over time, and retains suction characteristics
- discharge: Ø125mm
- power supply: 230V Mono
- motor power: 1hp, 0.75KW, 50HZ, 2.9A
- max flow: 450m³/h
- noise level: 66dB
- thermal protection switch
- rubber exhaust nozzle, 160mm opening, equipped with clamp, anti-intrusion isolation valve



MOBILE GAS VACUUM

AG 0084

Trolley extractor mounted on 4 swivel wheels, height-adjustable, equipped with a Y and a 1.25m hose with exhaust nozzle and clamp, as well as a delivery sheath and storage console.

This equipment enables you to work in a healthy environment, without inhaling exhaust fumes and in compliance with workplace safety standards.

2050 €VAT Excl.

Instead of 2199 €VAT Excl.*



Specifications:

- galvanized steel structure
- platform mounted on 4 swivel wheels for anti-tilt stability.
- epoxy paint (grey RAL 7040)
- 100 mm suction flange
- 1.25m of Ø100mm (-40° to +200°) high-temperature EPDM vulcanized fabric tubing.
- discharge: Ø 125mm length 10m
- power supply: 230V Mono
- motor power: 0.5hp, 0.37KW, 50HZ, 1.7A
- max flow: 250m³/h
- noise level: 66dB
- on/off switch
- exhaust nozzle equipped with anti-intrusion cloth, suction shut-off flap, for optimized suction on one mouth with access for Ø30mm opacimeter probe

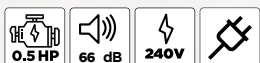

PNEUMATIC MOBILE GAS EXHAUST 5m Ø75mm

EG 0405

+ Small footprint



599 €VAT Excl.
Instead of 649 €VAT Excl.*

- adjustable height min. 15cm max. 55cm
- inlet Ø130mm
- evacuation hose length 5m Ø75mm, 200°C
- compressed air supply Ø10mm



DUAL EXHAUST SYSTEM GAS EXTRACTOR

EG 0406

Accessory of EG 0405

Essential for vehicles with two tailpipes, whether twin or on both sides of the vehicle.



250 €VAT Excl.
Instead of 312 €VAT Excl.*

Up to 200°C
Outlet: Ø90mm
Inlet: Ø52mm



METER CRUSH-PROOF 200°C EXHAUST PIPE Ø100mm

SA 3217 67 €VAT Excl.*

METER CRUSH-PROOF 200°C EXHAUST PIPE Ø150mm

SA 3219 89 €VAT Excl.*



Think about it !



DOUBLE HEADBAND HEADLAMP TN

OE 0199BL

+ Light and powerful



Buy x1

12

€VAT Excl.*

Buy x12

10

€VAT Excl.*

Per unit

Instead of 12 €VAT Excl.*

Specifications:

- 4 lighting modes
- COB LED lighting 10W
- 5W XPE LED spotlight
- wattage: 200-400lm (front) + 50-100lm (spot)
- dimmable
- battery type: 3.7 V 1200 mAh Li-ion
- mounting: adjustable stretch headband
- weight: 100g

 8
  4
  400
6000
  IK07
  IP 43
 
 USB-C

2
WARRANTY

NEW

MINI HAND LAMP TN

OE 0299

+ Pen format, fits in your pocket!



22

€VAT Excl.

Instead of 23 €VAT Excl.*

Specifications:

- double COB LED illumination
- indicator light
- battery: Li-ion 3.7V - 1200mAh
- mounting: belt + double magnet (back + base)
- dimensions: 27x15x97mm
- weight: 98g

 8
  3
  500
6000
  IK07
  IP 55
 
 USB-C

2
WARRANTY

NEW

WORKSHOP HAND LAMP TN

OE 0099BL

B.LINE
BUDGET SOLUTION

+ Multipurpose



Buy x1

16

€VAT Excl.*

Buy x12

14

€VAT Excl.*

Per unit

Instead of 16 €VAT Excl.*

Specifications:

- 5W COB LED lighting
- 3W SMD LED overhead light
- charge indicator
- battery: Li-ion 3.7V - 2000mAh
- articulated hand lamp, 180° inclination
- mounting: belt + hook + magnet
- dimensions: 33x46x165mm
- weight: 142g

 15
  3
  450
7000
  IK05
  IP 33
  180°
 
 USB-C

2
WARRANTY

NEW

EXTRA-FLAT INSPECTION LAMP TN

OE 0399

+ Ultra-thin! Only 10mm thick



33

€VAT Excl.

Instead of 35 €VAT Excl.*

Specifications:

- COB LED lighting
- indicator light
- battery: Li-ion 3.7V - 1800mAh
- mounting: hook + double magnet
- dimensions: 10x32x249mm
- weight: 120g

 8
  4
  360
6500
  IK07
  IP 54
 
 USB-C

2
WARRANTY

NEW

ULTRATHIN CORDLESS RECHARGEABLE LAMP WITH VARIABLE INTENSITY

TN

OE 0145BL

+ Economical

17,90 €VAT Excl.
Instead of 19,90 €VAT Excl.*

B.LINE
BUDGET SOLUTION



Specifications:

- ultra thin head: 23x14mm
- COB LED lighting
- power: 10-600lm
- dimmer (adjustable knob)
- battery type: Li-ion 3.7V - 2600mAh
- mounting: hook + magnet
- dimensions: 40x45x384mm
- weight: 175g



ULTRATHIN CORDLESS RECHARGEABLE LAMP WITH VARIABLE INTENSITY 7W IK07

TN

OE 0143

+ Precise light intensity

65 €VAT Excl.*

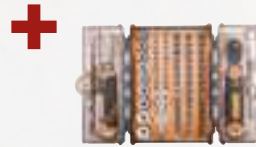

FREE FOR THE PURCHASE OF A SET OF 2 HAND LAMPS



Specifications:

- 7W COB LED lighting
- 3W head light (separate switch)
- dimmer (adjustable knob)
- battery type: Li-ion 3.7V - 2600mAh
- recharge: wall plug + USB-micro USB cable
- mounting: hook + magnet
- dimensions: 45x40x384mm
- weight: 260g



MOBILE SPOTLIGHT COB 1000LUMENS

TN

OE 0499

High lighting power in a small package!

32 €VAT Excl.

Instead of 34 €VAT Excl.*



+ 4000mAh high-capacity battery

180°

Fixation trépied + aimant

101mm



85mm

40mm

Specifications:

- LED COB + SMD lighting
- 4 levels
- load indicator
- battery: Li-ion 3.7V - 4000mAh
- mounting: magnet + articulated tripod support (180°)
- dimensions: 85x40x101mm
- weight: 265g



NEW



TN

DECK RAMP LAMP

OE 0899

ABS and TPU body: highly resistant to shock and abrasion!

Ideal on deck for powerful (1200Lumens!), targeted light thanks to 360° orientation

+ Powerful and optimal adjustment

55 €VAT Excl.
Instead of 59 €VAT Excl.*



NEW

Specifications:

- dual 10W COB LED illumination
- power: 80/1200 Lumens
- dimmer switch
- runtime: 2 to 15h
- charging time: 4.5h
- charge indicator
- battery: Li-ion 3.7V - 4000mAh
- charging: USB-C
- IP44 / IK07 protection
- mounting: double hook + double 360° rotating magnet
- dimensions: 39x47x520mm
- weight: 480g
- distance between magnets 420mm (handles folded)



RECHARGEABLE RAMP 1200LUMENS

OE 0179

The light ramp is quick and easy to install, so you can work hands-free under the hood or in the passenger compartment.

+ Two choices:
Powerful lighting: 1200Lumens
Soft lighting: 400Lumens



NEW

92 €VAT Excl.
Instead of 99 €VAT Excl.*

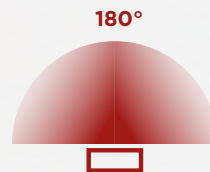

Specifications:

- ABS frame, adjustable length 115-180cm
- 180° light distribution with no shadows
- power: 400-1200 lumens
- dimmable (2 light levels)
- Kelvin: 5500 / 6500K
- runtime: 2.5 to 6h
- charging time: 4h
- battery type: 3.7V 4000mAh Li-ion
- IP52 / IK07 protection
- 360° swivel ramp
- 60mm wide anti-scratch hooks

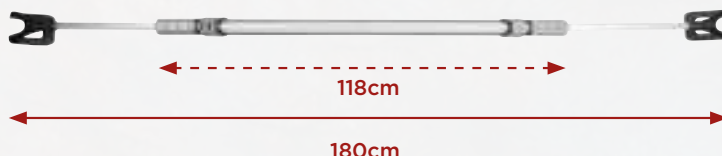

CABLE REELS 3x2,5mm² 20m

TN

OE 0428



Automatic cable distribution during winding

NEW

219 €VAT Excl.

Instead of 229 €VAT Excl.*

Specifications:

- 3x2.5mm² HO7RN-F-20m+1m cable
- capacity: 1000W-3000W
- cable guide with automatic distribution/ scanning
- free stop at desired length
- adjustable stop
- 180° rotatable wall bracket
- overtemperature and overvoltage protection
- -5°/+56° operating temperature
- polypropylene housing
- UV protection



20M



ELECTRICAL WIRE REEL 3x1.5mm² 10m

TN

OE 0053BL



Automatic cable distribution during winding

NEW

109 €VAT Excl.

Instead of 119 €VAT Excl.*

Specifications:

- cable 3x1.5mm² HO7RN-F-20m+1m
- capacity: 1000W-3000W
- cable guide with automatic distribution/sweep
- automatic 40cm locking (can be deactivated)
- adjustable stop
- 180° adjustable wall bracket
- overtemperature and overvoltage protection
- -5°/+56° operating temperature
- polypropylene housing
- UV protection



10M



B.LINE
BUDGET SOLUTION

ULTRASONIC CLEANER 9l 200W 40KHz

TN

OE 7201

699 €VAT Excl.*



TUB OF ULTRASOUND CLEANING SOLUTION CONCENTRATE 25% 2L

SA 7070 49 €VAT Excl.*

FREE

x2



Specifications:

- heating temperature adjustable from 0 to 80°C
- timer from 1 to 99 minutes
- power: 200W
- digital display
- tank drain valve
- tank capacity: 9l
- external dimensions: 330x310x270mm
- tray dimensions: 300x240x150mm



TN



VARIABLE BLOWGUN
BLACK METALLIC
NOZZLE

OP 0520 19 €VAT Excl.*



FREE
FOR THE PURCHASE OF
AN AIR REEL Ø10MM OR
Ø13MM

NEW

+ Automatic cable
distribution during
winding

Specifications:

- hose: Ø int. 10mm, braided PU hose (polyurethane)
- braked winding
- cable guide with automatic distribution/sweeping
- stopping device every 50cm (can be deactivated)
- PP (polypropylene) housing
- 1/4" connection
- 180° swiveling wall bracket
- operating pressure: 10bar

AIR REEL Ø10mm 15m

OP 1118

119 €VAT Excl.

Instead of 134 €VAT Excl.*

AIR REEL Ø13mm 15m

OP 1119

159 €VAT Excl.

Instead of 179 €VAT Excl.*



15M

15M



STRAIGHT BLOWGUN PEN

OP 0099

- pocket blowgun
- adjustable flow
- duralumin body
- length 110mm
- opening/closure by rotation



+ Always close
to hand

14 €VAT Excl.

Instead of 15 €VAT Excl.*



ROTATING NOZZLE CLEANING GUN

OP 0025

+ Rotary
flow



35 €VAT Excl.

Instead of 39 €VAT Excl.*



1/2» D. IMPACT WRENCH 1600Nm DOUBLE HAMMER

OP 1522BL

69 €VAT Excl.

Instead of 75 €VAT Excl.*



+ One-hand reverser



Specifications:

- dual hammer technology
- loosening torque: 1600Nm
- tightening torque: 850Nm
- speed: 8,500 rpm
- connection: 1/4"
- recommended hose Ø: 10mm
- supply pressure: 6.2bar
- consumption: 170l/min
- length: 185mm
- net weight: 2.1kg
- supplied with connector

B.LINE
BUDGET SOLUTION



1600Nm



1/2» D. IMPACT WRENCH SET 1600Nm FOR WHEELS (19 PCS)

OP 1550BL

139 €VAT Excl.

Instead of 159 €VAT Excl.*



+ All in one



Contents:

- OP1522BL: 1/2" impact wrench
- 3 special aluminium wheel sockets: 17-19-21mm
- 10 1/2" hexagon sockets: 9-10-11-13-14-17-19-22-24-27mm
- 1/2" extension 125mm
- 4mm hex key
- oil
- oiler
- pneumatic bit

B.LINE
BUDGET SOLUTION



1600Nm



TN

PACK TROLLEY JACK 2T + PAIR OF 2T JACK STANDS WITH SECURITY PIN

PACK.OH6302BL



OH 6302BL



OM 3002BL

83 €VAT Excl.

Instead of 105 €VAT Excl.*

B.LINE
BUDGET SOLUTION

Caractéristiques :

- H. mini : 268mm
- H. maxi : 418mm
- embase : 170x192mm
- poids : 4.8kg

Specifications:

- foot pedal
- anti-overload system
- iron wheels
- min. H.: 140mm
- max. H.: 490mm
- dimensions: 626x330x167mm
- weight: 29,5 kg

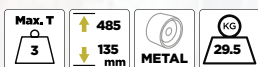

2T



TROLLEY JACK 2.25T

OH 5306

TN



179 €VAT Excl.

Instead of 199 €VAT Excl.*



Specifications:

- robust chassis
- metered release system for a precise load control
- safety overload system
- swiveling steel saddle
- swivelling rear casters
- h. min.: 140mm
- h. max.: 490mm
- dimensions: 645x345x185mm
- weight: 31kg



2.25T



FOOT PEDAL TROLLEY JACK 3T

OH 6303

TN



259 €VAT Excl.

Instead of 279 €VAT Excl.*

Specifications:

- foot pedal
- anti-overload system
- iron wheels
- min. H.: 140mm
- max. H.: 490mm
- dimensions: 626x330x167mm
- weight: 29,5 kg



3T



EXTRA FLAT TROLLEY JACK 3T 75mm

TN

OH 7014

+ Extra low profile



279 €VAT Excl.

Instead of 299 €VAT Excl.*

Specifications:

- foot pedal
- control lowering system
- safety overload system
- swiveling rubber saddle
- fast lifting dual pump system
- foam protection on handle
- PU front and rear wheels
- h. min: 75mm
- h. max: 510mm
- dimensions: 740x350x230mm
- weight: 32.5kg



3T

10 WARRANTY

PNEUMATIC FLOOR JACK 2T-2 STAGES

TN

OP 0209



+ Fast and effortless lift

Specifications:

- max. pressure: 7-10bar
- base: 240x240mm
- stroke: 235mm
- min. H.: 350mm
- max. H.: 115mm
- weight: 15kg



449 €VAT Excl.

Instead of 549 €VAT Excl.*

PNEUMATIC FLOOR JACK 2T-3 STAGES

OP 0309



Specifications:

- max. pressure: 7-10bar
- base: 272x220mm
- h. min. (without rubber pad and extension): 200mm
- h. max. (without rubber pad and extension): 500mm
- stroke: 300mm
- weight: 16kg



539 €VAT Excl.

Instead of 639 €VAT Excl.*

2T

2 WARRANTY

PAIR OF 3T JACK STANDS WITH SECURITY PINS

TN

OM 3030

49 €VAT Excl.

Instead of 52 €VAT Excl.*

- ### Specifications:
- min. H.: 276mm
 - max. H.: 420mm
 - base: 182x201mm
 - weight: 6.4kg



3T

2 WARRANTY

PACK PIT JACK 600kg + STRUT
COMPRESSION TOOL

PACK.OH0266



OH 0266



439 €VAT Excl. 
Instead of 658 €VAT Excl.*



OM 2033



Specifications:

- maximum capacity: 600kg
- POM (polyoxymethylene) clamping jaws to avoid damaging the shock absorber
- 3 depth adjustments
- adjustable in inclination
- specific jaws in option

Specifications:

- foot control
- chromed rod diameter 30mm
- overload safety
- deadman lowering control
- 4 swiveling wheels



600KG



1T FOLDABLE CRANE

OH 0336BL



B.LINE
BUDGET SOLUTION

249 €VAT Excl. 
Instead of 299 €VAT Excl.*

Specifications:

- lifting capacity: 0-2060mm
- 4 positions arm: 1000-750-500-250kg
- height feet: 185mm
- 6 rotating wheels

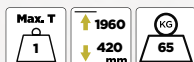

1T



1T LOW PROFILE FOLDABLE CRANE

OH 0335



3-position arm:
1000-800-700kg



+ Extra flat

469 €VAT Excl. 

Instead of 489 €VAT Excl.*

+ **FREE**



RECHARGEABLE
WIRELESS SPEAKER
PORTABLE LIGHT IK07

OE 0159 69 €VAT Excl.*

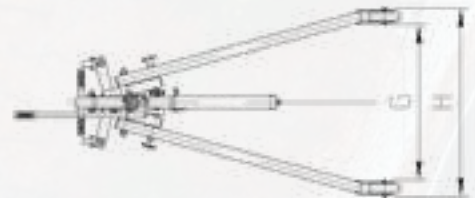
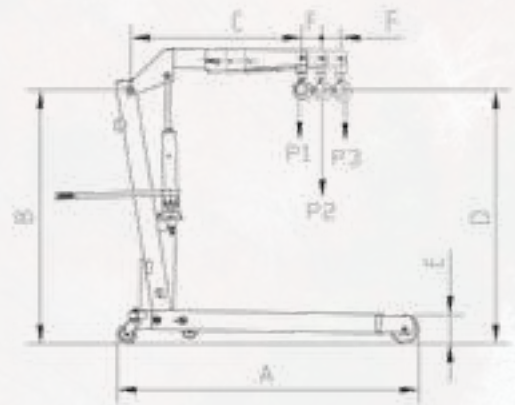

Specifications:

- double acting pump
- 360° rotating pump
- deadman lowering control
- 3 positions arm: 1000-800-700kg
- low profile: 85mm
- nylon wheels
- weight: 71kg



REF	Capacity (kg)	A (mm)	B (mm)	C (mm)	D1 (mm)	D2 (mm)	D3 (mm)	D4 (mm)
OH 0335	1T	1380	1400	1065	245-2230	100-245	0-2800	-

REF	E (mm)	F (mm)	G (mm)	H (mm)	I (kg)	J (kg)	K (kg)	L (kg)
OH 0335	85	100	88	870	1000	750	500	-

1T



TN

BOTTLE JACK 2T

OH 4502

Spare part of OH 9001

+ Robust & airtight thanks to the welded base



Specifications:

- min. height: 181mm
- max. height: 345mm
- soleplate adjustable from 0 to 48mm
- base: 99x93mm
- weight: 2.5kg



29 €VAT Excl.

Instead of 33 €VAT Excl.*



2T

BOTTLE JACK 4T

OH 4504

Specifications:

- min. height: 193mm
- max. height: 373mm
- soleplate adjustable from 0 to 60mm
- base: 110x103mm
- weight: 3kg



35 €VAT Excl.

Instead of 39 €VAT Excl.*



4T



500kg HYDRAULIC LIFT TABLE

OH 1300



1199 €VAT Excl.*

+ FREE

GREY/BLACK SLEEVELESS DOWN JACKET (L) (Choice of sizes: S to 3XL)

AP 7701 to AP 7706 62 €VAT Excl.*



Specifications:

- pedal hydraulic lift command
- dead man-type descent command
- tray dimensions 1010x520mm
- 2 fixed wheels and 2 swiveling wheels with protective casing and brakes
- h. min.: 440mm
- h. max.: 1575mm
- weight: 152kg



500KG



DUAL-CONTROL HYDRAULIC PRESS 30T SLIDING CYLINDER

OH 0931

+ Sliding jack
and winch

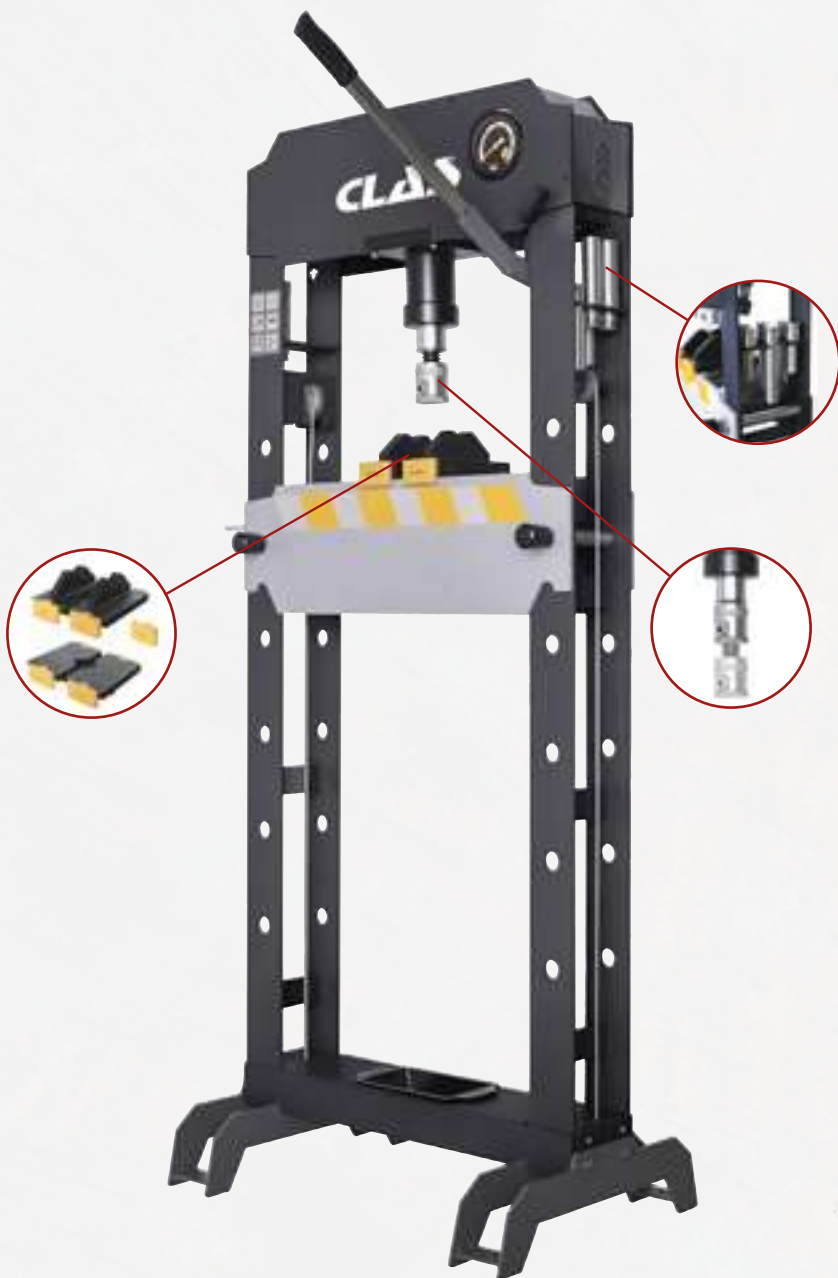

1999 €VAT Excl.*

+ FREE



ANGLE GRINDER 125mm
20V BRUSHLESS +
2 BATTERIES 4Ah +
CHARGER

PW 3125 269 €VAT Excl.*

Specifications:

- hydraulic pump
- manual override or hydropneumatic pedal
- chrome piston with adjusting screw
- sliding cylinder jack with handle and rating scale
- polycarbonate protection to protect the operator from splinters
- table height adjustable 12 positions
- winch-assisted up and down movement of the table
- 2 oversized pins to hold the table in place
- 226x136x55mm sliding drip tray
- large manometer
- reversible V-shaped support block, including punch kit and protective polycarbonate

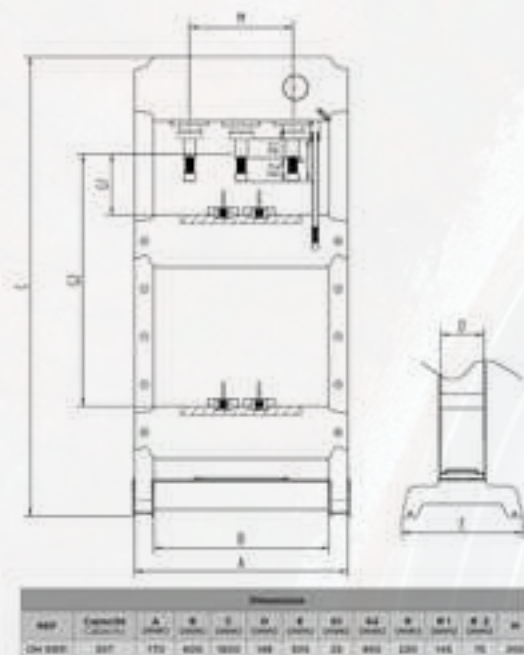

30T



7 DRAWERS + 172 TOOL ROLLER CABINET

EG 7205



EG 0087



OS 2000



OS 4100

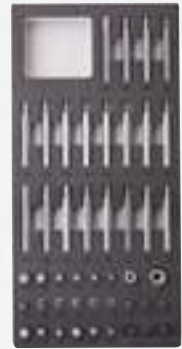

OS 6000



OS 1200



OS 1210



OS 3000



OS 3200



OS 5000

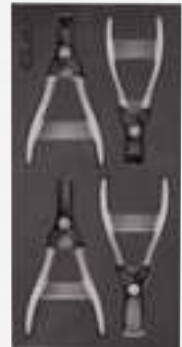

OS 5200

1179 €VAT Excl.*

+ FREE



1/2» CROSS TORQUE
WRENCH 70-170Nm
490mm + 3 SOCKETS

OM 0755 79 €VAT Excl.*



BLACK STRETCH MULTI-
POCKET PANTS WITH KNEE
REINFORCEMENT
(Choice of sizes: 36 to 46)

AP 7301 to AP 7306 62 €VAT Excl.*

Contents:

- EG0087 : 1 x 7 drawers roller cabinet
- EG4205 : 1 x 9 inserts 3 drawers 172 tool kit



4PCS MAGNETIC TOOL TRAY SET

EG 8004

Accessory of EG 0087/EG 0098/
EG 1100BL/EG 0088/EG 0097

22 €VAT Excl.
Instead of 33 €VAT Excl.*



Contents:

- 1 tray 310x110x120mm, load capacity 1.17kg
- 1 tray 270x110x120mm, load capacity 1kg
- 1 tray 210x110x120mm, load capacity 0.77kg
- 1 tray 150x110x120mm, load capacity 0.6kg



MAGNETIC SPRAY CAN AND SCREWDRIVER HOLDER

EG 8006

Accessory of EG 0087/EG 0088/
EG 0098/EG 0097

With strong magnets to firmly stick on metal tool boxes, this holder is made to hold 3 spray cans and 7 screwdrivers.

This holder is designed to allow the users creating new storage areas.

19 €VAT Excl.
Instead of 21 €VAT Excl.*



Specifications:

- 110x300x126mm
- load charge: 1.2kg



MAGNETIC TRAY

EG 8007

Accessory of EG 0087/EG 0088/
EG 0098/EG 1100BL/EG 0097



12 €VAT Excl.
Instead of 13,50 €VAT Excl.*

Specifications:

- ABS tray
- Ø148mm
- h.112mm
- 2 magnets Ø80mm



20 MAGNETIC HOOKS SET

EG 8008

Accessory of EG 0098/EG 0087/
EG 0088/EG 1100BL/EG 0097



21 €VAT Excl.
Instead of 23 €VAT Excl.*

Max. load: 800gr
per hook



TN

3 TRAY ROLLER CABINET

EG 0083



189 €VAT Excl.*

Specifications:

- overall dimensions: 766x415x840mm
- tray dimensions: 760x410x60mm
- 2 fixed casters Ø100mm
- 2 swiveling casters Ø100mm with brakes
- 2.5mm thick EVA foam tray protection
- admissible load per shelf: 30kg
- total admissible load: 90kg



MEN'S LONG-SLEEVED BLACK SHIRT (Choice of sizes: 36 to 46)

AP 8701 to AP 8706 35 €VAT Excl.*

FREE



1/4"-3/8"-1/2" TOOL SET (172PCS)

OS 3280BL

Intervention solutions for mechanical and industrial applications 1/4", 3/8" and 1/2".

119 €VAT Excl.*

Instead of 139 €VAT Excl.*



B.LINE
BUDGET SOLUTION



*Recommended user price applicable from 01/09/2024 to 31/08/2025. Illustrations non-contractual. Offer valid from 01/10 to 31/12/2024. In case of stock shortage, Clas reserves the right to deliver a gift of equivalent value.

Selection **FALL**

1/4"-1/2" TOOL SET (108PCS)

OS 3050BL

B.LINE
BUDGET SOLUTION

TN

99 €VAT Excl.*



BLACK DOUBLE-FLEECE BEANIE

AP 8500 19 €VAT Excl.*

FREE



TORQUE WRENCH 1/2" 40-210Nm 450mm

OM 0790BL

B.LINE
BUDGET SOLUTION

TN

69 €VAT Excl.*



BLACK DOUBLE-FLEECE BEANIE

AP 8500 19 €VAT Excl.*

FREE



+ Delivered with calibration certificate



TORQUE WRENCH 1/2" 40-220Nm

OM 0792

+ Delivered with calibration certificate

99 €VAT Excl.*



BLACK DOUBLE-FLEECE BEANIE

AP 8500 19 €VAT Excl.*

FREE



TN

MIXED OIL RECUPERATOR 90L

HU 0289

This oil recuperator performs oil changes by suction or gravity.



399 €VAT Excl.*



SET OF 24 PLUGS + NUT
WRENCHES PLASTIC DRAIN

CO 1095 145 €VAT Excl.*

FREE



Large capacity



Specifications:

- 150cm suction hose
- 150cm tank drain hose
- 5 flexible probes: Ø6/L. 700mm (2pcs); Ø8/L. 700mm (2pcs); Ø6/L. 900mm (1pc);
- suction drain: -2.5L.min
- power supply: 6 to 8bar
- Ø basin without extension: 370mm
- Ø basin with extension: 590mm
- basin equipped with retaining grid
- supply for tank discharge: 1bar
- level indicator
- weight: 25kg
- min. h. : 1400mm
- max. height: 1700mm
- storage box



90L



TN

90L MIXED OIL RECUPERATOR WITH PRECHAMBER

HU 0389N

This oil separator changes Engine oil by suction or gravity.

The graduated scale on the used oil collection bowl allows you to monitor the quantity of oil removed. Ideal for vehicles not equipped with a level control probe.

NEW



499 €VAT Excl.*



SET OF 24 PLUGS + NUT
WRENCHES PLASTIC DRAIN

CO 1095 145 €VAT Excl.*

FREE



Large capacity 90L + bowl



Specifications:

- 150cm suction hose
- 150cm tank drain hose
- 5 flexible probes: Ø6/L. 700mm (2pcs); Ø8/L. 700mm (2pcs); Ø6/L. 900mm (1pc);
- suction drain: -2.5L.min
- power supply: 6 to 8bar
- Ø basin without extension: 370mm
- Ø basin with extension: 590mm
- basin equipped with retaining grid
- pre-chamber capacity: 10L
- supply for tank discharge: 1bar
- level indicator
- weight: 30kg
- min. height: 1400mm
- max. height: 1700mm
- storage box



90L



BOOSTER 12V 2500A

OE 5051

419 €VAT Excl.

Instead of 479 €VAT Excl.*



+ FREE

PRECISION
RATCHET+SCREWDRIVER
SET (78PCS)

OS 1040BL 27 €VAT Excl.*



MEMORY SAVER OBDII
CIGARETTE LIGHTER

OE 0164 17 €VAT Excl.*



Compatible with all 12V vehicles

Specifications:

- peak current (HPCA): 1000A
- starting current (AC): 450A
- cold start current (CCA): 300-330A
- capacity: 22Ah
- cables: 25mm² (1.5in)
- integrated cigarette lighter socket
- charging time: 4-8h
- oversized and insulated copper/brass clamps
- Fuse integrated to the clamp
- shockproof ABS case
- battery : AGM
- weight : 10.6kg
- dimensions : 320x130x300mm



6/12/24V VEHICLE BATTERY TESTER WITH PRINTER

AC 5254

299 €VAT Excl.

Instead of 339 €VAT Excl.*



**+ Oscilloscope mode
Color display**

Specifications:

- capacity (CCA): cold-start current: 100 to 2000 CCA
- cables: L.2.5m
- clamps: insulated
- battery type : ordinary, AGM flat or spiral technology, GEL, EFB, LITHIUM.
- language : 12
- printer: SA 5245 coil
- weight: 2.07kg (with case)
- dimensions : L.255mmxL.104mmx36mm.

Battery standards :

- Cold Cranking Amps (CCA)
- International Electrot-Echnical Commission (IEC)
- Europe-Norm (EN)
- Deutsche Industrie-Norm (DIN)
- Cranking Amps (CA)
- Battery Council International (BIC)
- Marine Cranking Amps (MCA)
- Society Of Automotive Engineers (SAE)
- Japanese Industry Standard (JIS)

NEW



BATTERY CHARGER 1A

TN

OE 8001

34 €VAT Excl.

Instead of 39 €VAT Excl.*

Specifications:

- load: 1A
- charging voltage: 6/12V
- battery capacity: 4-30Ah
- charge holding capacity: 4-120Ah

Delivered with:

- crocodile clip
- additional cable with ring connection
- carrying pouch



1A



BATTERY CHARGER 4A

TN

OE 8004

54 €VAT Excl.

Instead of 69 €VAT Excl.*

Specifications:

- load: 4A
- charging voltage: 6/12V
- power: 70W
- battery capacity: 4-120Ah
- several modes available: 12V STD, 12V AGM, cold Mode, 12V M Mode, 12 VLFP Mode, 6V STD Mode, RECOND Mode, Supply Mode

Delivered with:

- crocodile clip
- additional cable with ring connection
- carrying pouch



+ Suitable for Lithium batteries



4A



BATTERY CHARGER 6A

TN

OE 8006

79 €VAT Excl.

Instead of 109 €VAT Excl.*

Specifications:

- load: 6A
- charging voltage: 6/12V
- power: 100W
- battery capacity: 4-150Ah
- several modes available: 12V STD, 12V AGM, cold Mode, 12V M Mode, 12 VLFP Mode, 6V STD Mode, RECOND Mode, Supply Mod

Delivered with:

- crocodile clip
- additional cable with ring connection
- carrying pouch



+ Suitable for Lithium batteries



6A



BATTERY CHARGER 10A

TN

OE 8010

89 €VAT Excl.

Instead of 129 €VAT Excl.*

Specifications:

- load: 10A
- charging voltage: 6/12V
- power: 160W
- battery capacity: 4-200Ah
- several modes available: 12V STD, 12V AGM, cold Mode, 12V M Mode, 12 VLFP Mode, 6V STD Mode, RECOND Mode, Supply Mode

Delivered with:

- crocodile clip
- additional cable with ring type connection
- 12V female plug
- carrying bag



10A



SMOKE LEAK DETECTOR

AC 0410

Thanks to its compact size, this machine is easily transportable, allowing intervention in the entire workshop. Its integrated compressor eliminates the need for an air supply. Compatible with the majority of the fleet, connected to the battery terminals, it allows quick diagnosis of the vehicle's closed circuits (turbo, exhaust, cooling, etc.).

To detect micro leaks on the circuits:

- vacuum
- exhaust
- turbo insulation
- oil pan
- admission
- cooling



Integrated compressor
Leak rate reading

This device considerably reduces leak detection time by diffusing an opaque, fine and instantly identifiable smoke on even the smallest leaks. Without any risk for the user and the vehicle.

Specifications:

- power supply: 12V
- output pressure: 1.2 bar for turbo system / 0.05 bar for exhaust system
- flow rate: 8L/min
- smoke control
- mode of operation: air only or smoke
- control manometer
- oil capacity: 50ml
- mineral oil (included)
- supplied with its accessories
- test fluid 250 ml = 35 hours of use
- weight: 6Kg
- dimensions: 260x210x230mm



Scan to
watch the
video

Contents:

- main unit
- accessory case
- adapter cone
- power cable
- smoke distribution pipe
- funnel
- universal adjustable intake bag
- bag replacement rubber
- test fluid (250 ml)
- oil filler cap adapter (for most BMW vehicles)
- smoke diffuser
- EVAP system accessory kit (fuel vapour recovery system)
- set of blanking plugs

1229 €VAT Excl. 
Instead of 1375 €VAT Excl.*



TN

PETROL INJECTOR CLEANER
300ml

CO 1005

High-performance fuel treatment:

- dissolves polluting deposits (calamine, gum, varnish...) for clean combustion for optimal performance
- lubricates and protects cylinders
- cleans the injection system



Treats up to 80 liters of fuel



Buy x1

13 €VAT Excl.*
Per unit

Buy x24

9,99 €VAT Excl.*
Per unit

Instead of 13 €VAT Excl.*

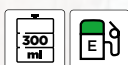

DIESEL INJECTOR CLEANER
300ml

CO 1010

High-performance fuel treatment for direct injection diesel engines, common rail...:

- dissolves polluting deposits (calamine, gum, varnish, combustion residues...) for clean combustion for optimal performance
- lubricates and protects mobile parts in diesel engines
- facilitates cold-starts
- cleans the injection system



Treats up to 80 liters of fuel



Buy x1

13 €VAT Excl.*
Per unit

Buy x24

9,99 €VAT Excl.*
Per unit

Instead of 13 €VAT Excl.*



BLACK SEALANT CARTRIDGE
-40/+250 DEGREES 200ml

CO 1020

Allows joints to be sealed (sump, water pump, gearbox) and mechanical parts (fuel pumps, carburetors).



Resistant to hydrocarbons



Buy x1

28 €VAT Excl.*
Per unit

Buy x12

19,99 €VAT Excl.*
Per unit

Instead of 28 €VAT Excl.*



BODYWORK DEGREASER 1L

CO 0506

+ Cleans and degreases all types of dirt.

Specifications:

- compatible with all surfaces
- dries quickly, leaving no residue
- easy to use
- cleans and degreases all types of dirt
- liquid Fluid
- dilutable
- PH in aqueous solution: at 15% = 13,1



Buy x1

12 €VAT Excl.*
Per unit

Buy x24

9 €VAT Excl.*
Per unit

Instead of 12 €VAT Excl.*



Allows application without primer on any support (metal, plastic and aluminum). Removes unevenness, provides a homogeneous and uniform surface before sanding. Filling up to 120µ



+ Fast drying time
Quick sanding

Buy x1

12 €VAT Excl.*
Per unit

Buy x12

8,50 €VAT Excl.*
Per unit

Instead of 12 €VAT Excl.*

- DARK GREY GARNISHING PRIMER 500ml
CO 1001
- LIGHT GREY FILLER PRIMER 500ml
CO 1042
- BLACK FILLER PRIMER 500ml
CO 1044



NO RUST SPRAY 400ml

CO 1035

Stops rust developing on bodywork and running gears. For preventative and curative use.

+ Transparent



Buy x1

12 €VAT Excl.*
Per unit

Buy x12

9 €VAT Excl.*
Per unit

Instead of 12 €VAT Excl.*



BODY REPAIR ROLLER CABINET

190 TOOLS

EG 8888

2049 €VAT Excl.*

+ FREE



CAMEL TEDDY
STRETCH JACKET
(Choice of sizes: S
to 3XL)

AP 8601 to AP 8606 69 €VAT Excl.*



OS 4100

OS 3000

OS 5000



OS 3200

OS 0850

OS 2000

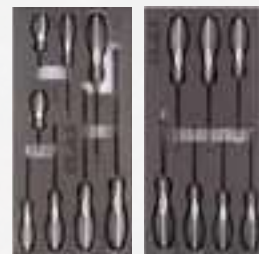

OC 6081



OC 6080

Contents:

- EG0087 : 1 x 7 drawers roller cabinet
- OC0811 : 1 x hammer + block set (7 pcs)
- OM0749BL : 1 x riveting pliers
- SA0115 : 1 x plastic chisel
- OC0033 : 1 x trim clip plier
- OM8081 : 1 x lock grip plier 190mm
- OM8080 : 1 x lock grip pliers 225mm
- OP1510 : 1 x 1/4»-3/8» d. mini ratchet wrench kit
- OP1203 : 1 x mini die grinder ø6mm 25,000rpm
- OM0643 : 1 x 5 carbide rotary rasps box
- EG0680 : 1 x drill set hss cobalt 5% (25pcs)
- EG8009 : 1 x dispenser/hand towel roll stand for drawers
- EG8001 : 1 x metal workshop waste for drawer
- OS3200 : 1 x ratchet insert 1/4» (59 pcs)
- OS4100 : 1 x combination wrench insert 6-24mm (17 pcs)
- OS3000 : 1 x 1/2» ratchet insert (23 pcs)
- OS5000 : 1 x plier insert (4 pcs)
- OS2000 : 1 x hex t-handle wrench insert 3-10mm (7 pcs)
- OC1700BL : 1 x windscreen wiper remover
- OC0302 : 1 x scraper and utility knife set
- OC8078 : 1 x 5 pcs nylon trim removal set
- SA0881 : 1 x hammering insert
- OM0801 : 1 x 6 pin driver set with base
- OM0803 : 1 x automatic punch
- OM0160 : 1 x rivoir hammer composite handle 1000gr
- OM0170 : 1 x dead blow hammer with interchangeable tip 32mm
- OM0800 : 1 x extra flat splitting chisel
- OP1451 : 1 x ø13mm reversible drill
- OC6081 : 1 x wide bodywork spoon
- OC6080 : 1 x long bodywork spoon
- OP0099 : 1 x straight blowgun pen
- OS1200 : 1 x diamond screwdriver insert ph-slotted (8pcs)
- OS1210 : 1 x 7 pcs t10-40 diamond torx screwdriver insert



WINDSHIELD REPAIR KIT

EG 9988

The Contents can be used to fit and remove bonded or beaded windscreens, as well as to repair impact damage.

You can work in different ways:

- with the cutting knife, using manual traction
- with single- or 2-operator ropes

The servo unit is ideal for creating a windshield-dedicated business, with an ergonomic, all-in-one workstation.



2099 €VAT Excl.

Instead of 2299 €VAT Excl.*



OS 3200



OS 3000



OS 4020

Drawer n°1



Drawer n°4

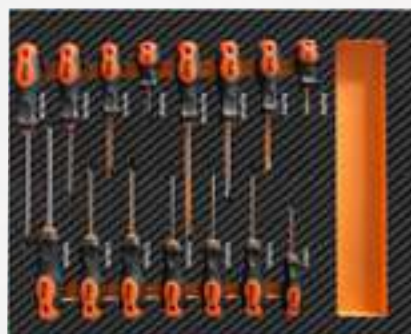

Drawer n°2



Drawer n°5

Contents:

EG0086: 6-drawer trolley

• drawer 1 conventional hand tool

OS3200: 1/4» ratchet insert

OS3000: 1/2» ratchet insert

OS 4020 combination wrench insert

• drawer 2

EG1101BL: screwdriver insert

• drawer 3

OC1409: dashboard protectors 4pieces

OC 2204 universal rain/headlight sensor gel x5

OC5071: cartridge gun

• Drawer 4 Windshield Cutting Inserts OC3351

SA9987: Windshield Cutting Foam Insert

OC0302: Scraper and Cutter Set

OC0200: Gasket Cutting Knife

OC7025: Box of 5 25mm Blades

OC7038: Box of 5 38mm Blades

OC2900: Pair of Pull Handles

OC2100: Braided Wire Reel

OC3100: square wire feeder

OC6000: Wire Locking Lever

OC4100: Wire Passing Tool

OC0304: Handle Scraper

OC5497: 100pc Trimmer Blades

• Drawer 5 Windshield Intervention Insert OC3352

OC0501: Rope Insertion Tool

OC0502: Windshield Mounting Tool

OC8078: 5-piece Nylon Spatula Kit

OC1700: Wiper Blade Remover

EG0002: Washer Nozzle Cleaning Tool

OC0600: Pair of Suction Cups

OC3350: Angled Round Butt Joint Tool

• Drawer 6

OC2203: Windshield Repair Kit

OC8067: Carbide Bit

• side storage

EG8001: Metal Workshop Bin

OC3360: 50m Adhesive Film

NEW



TN

BODYWORK STAND WITH TARPAULIN

OC 0724

Equipped with a tarpaulin to hold tools or other items, it can also be used to protect parts such as hoods, bumpers, wings, etc...

+ Foam protection



79 €VAT Excl.*

+



PAIR OF SUCTION CUPS Ø115mm

OC 0550BL 59 €VAT Excl.*

FREE

Specifications:

- capacity: 270kg
- folding galvanized steel structure (Ø32mm x 1.2mm).
- height: 1040mm
- width: 1080mm
- working range from 680 to 1040mm (adjustable feet)
- PU support plug
- weight: 6.4kg



TN

UNIVERSAL TELESCOPIC BODYWORK STAND 23-138cm

OC 0716



229 €VAT Excl.

Instead of 249 €VAT Excl.*

Specifications:

- width: 22.5 à 138cm
- height: 84 à 132cm
- anti-slip rubber-sheathed support arm
- support arm length: 86cm
- support arm width: 8cm
- capacity: 100kg
- 4 swiveling wheels, 2 of which have brakes



+ Does not scratch paintwork



TN

SCRAPER AND UTILITY KNIFE SET

OC 0302

29 €VAT Excl.

Instead of 34 €VAT Excl.*



Contents:

- 1 cutter
- 5 straight blades 12mm (OC5301)
- 5 straight blades 16mm (OC5302)
- 5 straight blades 20mm (OC5303)
- 5 bevelled blades 16mm (OC5304)
- 5 trapezoidal blades (OC5305)



LONG BODYWORK SPOON

OC 6080



Specifications:

- forged steel
- length: 335mm
- width: 45mm

49 €VAT Excl.*

+ WIDE BODYWORK SPOON

OC 6081 45 €VAT Excl.*

FREE



TN

HAMMER + BLOCK SET (7 PCS)

OC 0811



+ Hickory handle

Contents:

- 3 hammers with GENUINE HICKORY handles L.310mm:
- OC0812: planishing hammer with round flat head and pointed tip
- OC0813: planishing hammer with round flat head straight tip
- OC0814: cornering hammer with round and square gridded head

4 blocks:

- OC0815: comma 130x27mm
- OC0816: rail/universal 60x60x56mm
- OC0817: claw 78x60x27mm
- OC0818: anvil 80x62x55mm

169 €VAT Excl.*

+ MEN'S LONG-SLEEVED BLACK SHIRT (Choice of sizes: 36 to 46)

AP 8701 to AP 8706 35 €VAT Excl.*

FREE



TN

AIR HYDRAULIC PUMP 10T 1/4"

OH 0014

Accessory of OH 9150
Spare part of OH 9150



Delivered without hose (SA0802)



490 €VAT Excl.*

+ BLACK TEDDY STRETCH JACKET (Choice of sizes: S to 3XL)

AP 7603 69 €VAT Excl.*

FREE



TN

BODYWORK CYLINDER SET PUSHER/PULLER 1/4"

OC 0705



Contents:

- SA0704: pusher cylinder 2T H. min. 132mm/H.max. 189mm
- SA0706: pusher cylinder 4T H.min. 275mm/H.max. 405mm
- SA0703: mini puller cylinder 4T H. min. 42mm/H.max. 58mm
- SA0705: mini puller cylinder 10T H. min. 132mm/H. max.

189mm

- SA0707: pusher cylinder 10T H. min.350mm/H. max. 500mm
- SA0709: puller cylinder 2T L.max. 550mm/L.min. 422mm
- SA0708: puller cylinder 5T L.max. 650mm/L. min. 520mm

499 €VAT Excl.

Instead of 599 €VAT Excl.*



TN

CENTRAL VACUUM CLEANER 2x1300W

EG 0055

Accessory of OE 1319/OE 1318

Vacuum cleaner that can also be used as a central vacuum cleaner. Compatible with pneumatic and electric tools up to 1200W.

+ Automatic filter cleaning at each use



1390 €VAT Excl. 
 Instead of 1550 €VAT Excl.*

Specifications:

- 76L plastic tank mounted on 4 castors trolley
- 2 motors 1300W
- tool tray 600x480mm
- hose Ø28mm 4.5m with integrated pneumatic hose
- depression 23,5kPa
- air flow rate: 119l/s
- noise level: 68dB
- dimensions: 580x590x940mm

Accessories included:

- SA0405: hose Ø28mm 4.5m
- SA0406: filter

Options:

- SA0409: 5 bags 77L
- SA5505: flexible Y-adaptor for 2 operators
- SA5506: Y-pneumatic adaptor for 2 operators



*Recommended user price applicable from 01/09/2024 to 31/08/2025. Illustrations non-contractual. Offer valid from 01/10 to 31/12/2024 In case of stock shortage, Clas reserves the right to deliver a gift of equivalent value.

TN

PAIR OF MECHANICAL DOLLIES 1180kg

OM 2034

Ideal for effortlessly moving vehicles that have broken down or are parked in tight spaces.



+ A single operator



249 €VAT Excl. **»»»**
Instead of 299 €VAT Excl.*

Specifications:

- lifting assisted by mechanical rack
- steel rollers L.280mm
- 4 wheels, 2 with brakes
- capacity: 1180kg
- working area: 340-710mm
- minimum and maximum wheel diameter: 450-810mm
- max capacity width: 11" (280mm)
- weight: 15.9kg



HYDROPNEUMATIC MOBILE LIFTING COLUMN 1500kg

OH 9150

TN

1199 €VAT Excl. **»»»**
Instead of 1349 €VAT Excl.*



Specifications:

- 2 swivel wheels to facilitate handling
- safety pin: 5 secure heights
- lifting by the wheel or the car body
- mobile and fast

Supplied with:

- SA9151: lifting under the wheel
Max. working height: 735mm
Min. height: 100mm
Wheel diameter from 480 to 730mm
- SA9152: lifting under the car body
Max. working height: 835mm
Min. height: 140mm

+ Allows the vehicle to be lifted in less than a minute.



1.5T

