

2024 - 2025

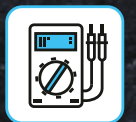

CLAS[®]
GLOBAL GARAGE SOLUTIONS

Solutions
**HYBRID &
ELECTRIC**

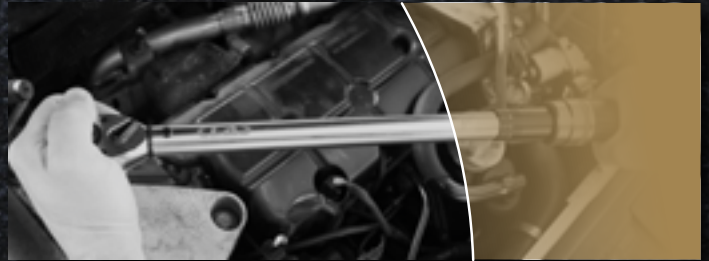

437

HYBRID & ELECTRIC

Browse through our HYBRID & ELECTRIC solutions, from our 24-25 general catalog.



444 - PROTECTION



447 - SIGNS

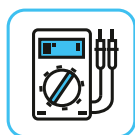

451 - ELECTRONICS



454 - INSULATED TOOLS

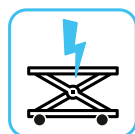

458 - LIFTING



465 - REELS & LOAD



You can find our full range on **clas.com** (or in our general catalog)

WORKING ON HYBRID AND ELECTRIC VEHICLES

The automotive market has undergone a significant transformation in recent years, marked by the growing adoption of hybrid and electric vehicles.

Nearly **150 million electric and hybrid vehicles will be on the road worldwide by 2030!** Equipment adapted to these vehicles is now essential.

CLAS is mobilizing its research and development teams to meet market demand, while complying with current standards.



WHAT HAZARDS?

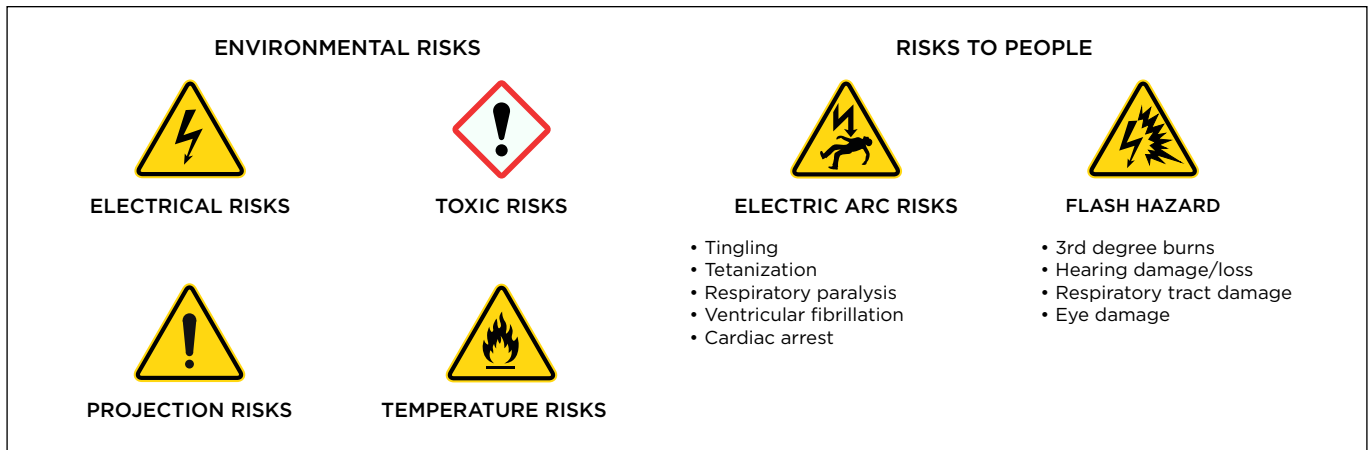

During their lifecycle (from sale to dismantling), HEVs have to undergo a number of interventions to ensure their longevity.

To intervene, it is essential to:

- Comply with current standards (NF C18-550)
- Be informed, trained and authorized
- Be equipped

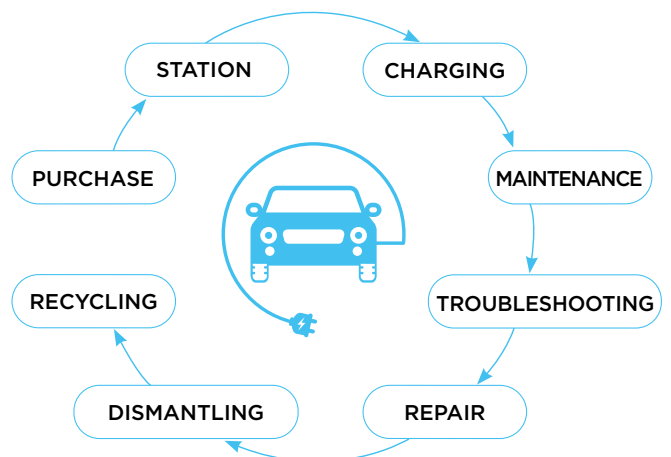

ELECTRICAL CERTIFICATIONS

They are essential to guarantee safety when working on hybrid and electric vehicles. Here are the main types of authorization and their uses.

- **BOL** : Basic certification where the user is warned of the electrical risks involved in carrying out work on a mechanical source.
- **BCL** : Habilitation for consignment, the safe de-energizing of the vehicle for work purposes.
- **B1VL, B2VL** : Certification for consignment, i.e. the safe de-energizing of the vehicle for work purposes.
- **B1XL, B2XL** : Certification for technical control, breakdown and towing services, personnel managing the dismantling of electric or hybrid vehicles, or those responsible for vehicle homologation and crash testing.
- **B1TL, B2TL** : Certification to work on the vehicle's traction battery (under voltage)

CLAS has the right equipment for every need and every certification



AUTHORIZATIONS	BCL/B1VL/B2VL	B1XL/B2XL	B1TL/B2TL
Type of intervention	<ul style="list-style-type: none"> • Consignment • De-energized electrical work 	<ul style="list-style-type: none"> • Special intervention 	<ul style="list-style-type: none"> • Energized electrical work
Professions	<ul style="list-style-type: none"> • Technician/diagnostics • Painter • Bodywork • Depollution/recycling 	<ul style="list-style-type: none"> • Rescue/emergency • Breakdown/towing • Technical inspection • Depollution/recycling 	<ul style="list-style-type: none"> • Technician/diagnostics • Depollution/recycling
Dedicated pack	OE 0376	OE 0377	OE 0378



ELECTRICAL CERTIFICATION SETS

TN

BCL/B1VL/B2VL

★ **TOP PRODUCT**

NEW

ELECTRIC/HYBRID VEHICLE CONSIGNMENT PACK

OE 0376

This kit is dedicated to professionals working on live electrical work.
Dedicated to consignment officers.



OE 3010



OE 0564



OE 3011

OE 3012

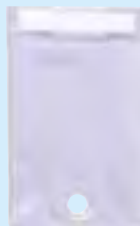

OE 0757

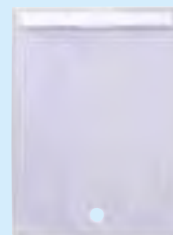

OE 0758



OE 0764



EG 3110



OE 0840



OE 0562



OE 0563



EG 0031



EG 0035

Contents:

- EG3110: tool bag with shoulder strap
- OE3010: VAT safety tester
- OE3011: IP2X black probe
- OE3012: IP2X red touch point
- OE0562: lockout bag
- OE0564: lockout padlock
- OE0563: locking disc
- OE0757: insulating bag for 210mmx130mm connector
- OE0758: insulating bag for 305mmx225mm connector
- EG0031: flying hazard cover
- EG0035: electrical danger sign micro suction cup 200mm
- OE0764: self-gripping insulating sheet 660mmx360mm





TN

B1XL/B2XL

NEW

This kit is dedicated to professionals working on specific jobs.
Dedicated to tow trucks, wreckers/recyclers, technical control, firefighters.



OE 0844



OE 0840



OE 0764



OE 0562



EG 0031



OE 0563



OE 0564

OPTION 1

PACK E-MOBILITY ELECTRIC/
HYBRID VEHICLE

OE 0377



EG 3120

OR

OPTION 2

PACK E-MOBILITY BACKPACK
ELECTRIC/HYBRID VEHICLE

OE 0379



EG 3130

Contents:

- OE0840: 1000V insulated tool set for hybrid and electric vehicles (27pcs)
- OE0764: 660mmx360mm self-gripping insulating blanket
- OE0844: (x4) : insulated fixing clamp
- OE0562: lockout bag
- OE0564: lockout padlock
- OE0563: locking disc
- EG0031: hazard steering wheel cover
- EG3130: backpack ou EG3120 : wheeled suitcase



1000V

TO CONSIDER!

ELECTRICAL INDIVIDUAL PROTECTION
EQUIPMENT MASTER SET

OE 0342



1000V

VOLTAGE SAFETY TESTER

OE 3010



IP 65

0,9 m

2
WARRANTY

RED TOUCH POINT IP2X
FOR VAT DEVICE

OE 3012

Accessory of OE 3010



BLACK TOUCH POINT IP2X
FOR VAT DEVICE

OE 3011

Accessory of OE 3010

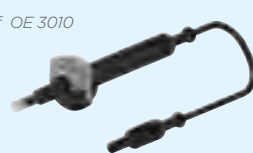
2
WARRANTY



B1TL/B2TL

NEW

ELECTRIQUE/HYBRIDE VEHICLE UNDER VOLTAGE OPERATION SET

OE 0378

This kit is dedicated to professionals involved in live electrical work. Dedicated to consignment supervisors, body repairers/painters, diagnostic technicians, paint strippers/recyclers, etc.



EG 0076



OE 0660



OE 0683



OE 0820



OE 0850



OE 0870



OE 0880



EG 0080

4 DRAWERS + 1 DOOR ROLLER CABINET HGV

EG 0076

Specifications:

- dimensions: L.881xW.460xH.858mm
- 100% drawer opening
- 4 drawers H.75mm int.774x400mm
- 1 pedestal H.540mm int.774x450mm
- wooden top
- ball-bearing runners
- ABS drawer handles
- key lock (2 keys supplied)
- wheels on sealed bearings
- 2 fixed wheels Ø125mm
- 2 Ø125mm swivel wheels, 1 with double brake (rotation + swivel)
- load capacity per drawer: 40kg
- total load capacity: 500kg

Contents:

- EG0076: 4-drawer trolley + 1 PL box
- OE0660: 1/4" insulated ratchet and socket inserts (46 pcs)
- OE0683: insulated flat wrench insert (15 pcs)
- OE0820: 3/8" insulated ratchet and socket inserts (14 pcs)
- OE0850: insulated 12-sided offset wrench inserts (11 pcs)
- OE0870: insulated pliers insert (4 pcs)
- OE0880: insulated screwdriver inserts (7 pcs)
- EG0080 (x2): foam storage box





TO CONSIDER!

MARKING/WORK AREA SIGNALING SET

TN

EG 0012



ELECTRICAL INDIVIDUAL PROTECTION EQUIPMENT MASTER SET

TN

OE 0342



INSULATED TORQUE WRENCH 1/4" 5-25Nm

TN

OE 0841

NEW

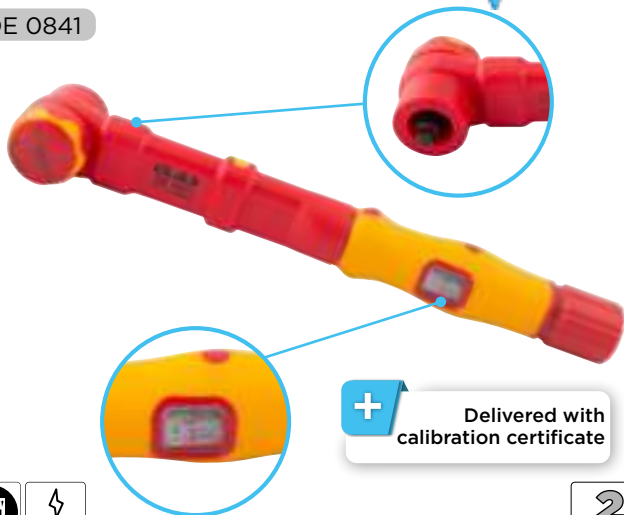

+ Delivered with calibration certificate



INSULATED TORQUE WRENCH 3/8" 10-50Nm

TN

OE 0842

NEW



+ Delivered with calibration certificate



MEGOHMMETER 1000V CAT. III & 600V CAT. IV

TN

OE 4002

Suitable for the "low voltage" requirements of authorisations:
BCL, B2VL, B2TL, B2XL ...

Specially designed for hybrid and electric vehicles, this device can measure the isolation of electrical equipment, as well as a voltage up to 1000V.

It allows the measurement of DC and AC voltage, DC and AC current, temperature, resistance, capacity, isolation and frequency.

Contents:

- 1x Megohmmeter
- 1x pair of measuring cables
- 1x pair of crocodile clips
- 1x MS 3204
- 1x temperature probe (Thermocouple type K)
- 1x transport house
- 1x transport strap (shoulder strap)
- 4x LR6 batteries





HYBRID & ELECTRIC PPE

ELECTRIC ARC PROTECTION JACKET

TN

NEW

OE 0650	S
OE 0651	M
OE 0652	L
OE 0653	XL
OE 0654	2XL



Specifications:

- Arc flash class 1, ATPV 12 cal/cm², - Standards: EN standards: EN 13034 : 2005 / EN 1149-5 : 2008 / EN ISO 11611 : 2007 / EN ISO 11612 : 2008 / IEC 61482-2 : 2009 (CLASS 1 AND ATPV 12 cal/cm²)
- Contents: 79% cotton, 20% polyester, 1% antistatic fiber, 300 gr/m²
- ATEX zone

NO WARRANTY

ELECTRIC ARC PROTECTION PANTS

TN

NEW

OE 0640	38
OE 0641	40
OE 0642	42
OE 0643	44
OE 0644	46
OE 0645	48
OE 0646	50



Specifications:

- arc flash class 1, ATPV 12 cal/cm².
- standards: EN 13034: 2005 / EN 1149-5: 2008 / EN ISO 11611: 2007 / EN ISO 11612: 2008 / IEC 61482-2: 2009 (CLASS 1 AND ATPV 12 CAL/CM²)
- Contents: 79% cotton, 20% polyester, 1% antistatic fiber, 300 gr/m².
- ATEX zone

NO WARRANTY



FACIAL PROTECTION SCREEN FOR ELECTRICAL ARCS

TN

OE 0311

Class 1B8
Colorless
2C-1.2 U 1 AT 8 9 0068 CE



Specifications:

- conforms to standard EN 166, EN 170
- liftable anti-scratch screen with ventilated forehead protection
- double-setting ear muffs
- ultraviolet filter
- screen thickness: 1.5mm
- weight: 380g



ELECTRIC ARC PROTECTION HELMET WITH RETRACTABLE FACE SHIELD

TN

OE 0312

Face protection against thermal effects and flash, consequences of electric arcs.



+ A compact, lightweight combination



PAIR OF INSULATED GLOVES CLASS 0 T10

OE 0310

PAIR OF INSULATED GLOVES CLASS 0 T9

OE 0309

Pair of 3 in 1 natural rubber insulated gloves. Contrary to most of the gloves on the market, this pair of gloves is specially designed for working on electric and hybrid vehicles. Ergonomic, the gloves respect perfectly the natural position of the hand.

Moreover, the thickness of these gloves is reduced to the maximum, thus increasing comfort of use and dexterity when handling small parts. This pair of gloves offers triple protection: electrical, mechanical and thermal.

To ensure optimal use, it is important to choose the right glove size, please refer to the table on the left.

Specifications:

- length : 36 cm
- 3 in 1 composite glove : mechanical, electrical and thermal resistance (ARC-FLASH)
- embossed palm and fingers for an optimal grip, even in wet or greasy conditions
- AZC category (acid, ozone, very low temperature resistance)
- EN60903 standard (double triangle logo): suitable for work under electrical voltage
- EN388 standard (hammer logo in a shield): mechanical resistance according to the standard
- standard EN61482-1-2: protective clothing against the thermal dangers of an electric arc
- CE marking O333: PPE category III (risk of death or irreversible injury) - PPE of complex design
- class 0: protection against 1000V alternating current and 15000V direct current.

+ Comfort, dexterity, triple protection



3 IN 1

EN 60903 class 0 ELECTRICAL RISKS	IEC 61482-1-2 ELECTRIC ARC RISKS	EN 388 MECHANICAL RISKS





PAIR OF 1000V INSULATING GLOVES

OE 0302

Size 10

Compatible with authorizations: B1L, B1VL, B1TL, B2L, B2VL, B2TL, BCL, BEL, BRL, B1XL, B2XL
Standard : EN 60903



TN

PNEUMATIC TESTER FOR INSULATING GLOVES

OE 0306



Small footprint, ergonomic

TN

LEATHER OVERGLOVES FOR INSULATED GLOVES

OE 0303

Size 10

Standards: EN-388

Compatible with authorizations: B1L, B1VL, B1TL, B2L, B2VL, B2TL, BCL, BEL, BRL, B1XL, B2XL.



Specifications:

- compatible with OE 0309 and OE 0310 gloves
- Ø handle: 100mm



PERSONAL ELECTRICAL PROTECTION EQUIPMENT SET

OE 0332

OE 0311



OE 0310



Contents:

- OE 0311: 1 arc protection face shield
- OE 0310: 1 pair insulating gloves class 0 T10

Specifications:

- compatible with authorizations: B1L, B1VL, B1TL, B2L, B2VL, B2TL, BCL, BEL, BRL, B1XL, B2XL.

TN

ELECTRICAL INDIVIDUAL PROTECTION EQUIPMENT MASTER SET

OE 0342

This PACK includes a pair of composite gloves, an ARC FLASH visor and all the additional equipment necessary to ensure the protection and safety of your PPE.

As this equipment is intended to protect you from electrical risks, it is essential to take care of it and to check it regularly.

Contents:

- OE 0311: 1 arc protection face shield
- OE 0566: 1 cover for helmet or face shield
- OE 0567: 1 cover for gloves & under-gloves
- OE 0310: 1 pair insulating gloves class 0 T10
- OE 0306: 1 pneumatic insulating glove checker



OE 0306



OE 0566



OE 0567



OE 0310

OE 0311



TN



HYBRIDE & ELECTRIQUE CPE

MARKING/WORK AREA SIGNALING PACK

EG 0012



EG 0015



EG 0019

Contents :

- 6 yellow and black sign posts
- 1 yellow and black chain
- 1 "work zone limit" banner



Compatible with authorizations:
B1L, B1VL, B1TL, B2L, B2VL, B2TL,
BCL, BEL, BRL, B1XL, B2XL.

TN

COLLECTIVE PROTECTION EQUIPMENT MASTER SET

EG 0001



EG 0015



EG 0031

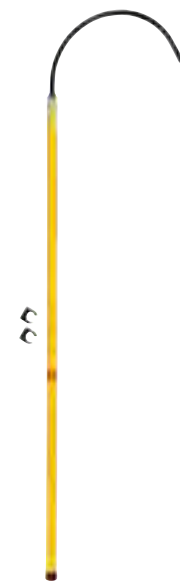

OE 0720



EG 0019

Contents :

- 6 yellow and black sign posts
- 1 yellow and black chain
- 1 "work zone limit" banner
- 1 "danger" steering wheel cover
- 1 insulated rescue pole



TN





SIGNAGE BANNER "WORK ZONE BOUNDARY" 100x20cm

TN

EG 0015



Specifications:

- 4 eyelets + 2 fixing cords
- coated fabric
- dimensions: 100x20cm

Compatible with authorizations: B1L, B1VL, B1TL, B2L, B2VL, B2TL, BCL, BEL, BRL, B1XL, B2XL.



WORKING AREA DELIMITATION SET 25m

TN

EG 0019

NEW



Pole specifications:

- height: 90cm
- tube diameter: 4cm
- base diameter: 34cm
- weight: 3.2kg

Chain Specifications:

- length: 25m
- thickness: 0.8mm

Certification compliant: B1L, B1VL, B1TL, B2L, B2VL, B2TL, BCL, BEL, BRL, B1XL, B2XL.



PLASTIC SIGNALING CHAIN YELLOW/BLACK 25m

TN

EG 0013

Accessory of EG 0014

Allows a work zone or a dangerous area to be delimited...

Ø links: 6mm

+ Interior and exterior use



SIGNPOSTING REEL 20m

TN

EG 0017



ADHESIVE SIGNALING AND SAFETY VINYL TAPE 33m W.50mm

TN

EG 1050



ELECTRICAL DANGER SIGN SUCTION PAD 200mm

TN

EG 0035



Compatible with authorizations: B1L, B1VL, B1TL, B2L, B2VL, B2TL, BCL, BEL, BRL, B1XL, B2XL.





INSULATING SHEET 3/10th
12.5x1.3m

OE 0755

Allows temporary insulation in order to install parts and conductors which are exposed or insufficiently insulated.

Specifications:

- max. voltage: 1000V AC
- material: Insulating, fireproof PVC
- thickness: 3/10th
- dimensions: 12.5x1.3m

Compatible with authorizations: BIL, BIVL, BITL, B2L, B2VL, B2TL, BCL, BEL, BRL, B1XL, B2XL.
Conforms to standards ST TST BT 420 and IEC 61112 category 0 (1000V).



TN

INSULATED CLAMP

OE 0844

For securing temporary protective coverings such as insulating blankets

NEW



OE 0757

OE 0758

INSULATING SLEEVE FOR CONNECTOR 210mmx130mm

OE 0757

INSULATING SLEEVE FOR CONNECTOR 305mmx225mm

OE 0758

Specifications:

- temporary protection
- electrical standard: CEI 60900
- dimension: 225x305mm
- transparent



SELF-GRIPPING INSULATING SHEET
660mmx360mm

OE 0764



Specifications:

- temporary protection
- standard: CEI 60900

+ Electrical insulation ,
Velcro , secure





← FIND THE ALL **HYBRID & ELECTRIC ACCESSORIES** RANGE HERE



NEW

OE 0845	4 INSULATED CAPS Ø10mm
OE 0846	4 INSULATED CAPS Ø20mm
OE 0847	4 INSULATED CAPS Ø30mm
OE 0848	4 INSULATED CAPS Ø60mm



1000V **NO WARRANTY** **TN**

CLASS 0 INSULATING MAT - 100x60cm

OE 0750

+ Ultra light weight



Specifications:

- max. voltage: 1000V AC
- thickness: 1,5mm
- dimensions: 100x60cm

1000V **NO WARRANTY** **TN**

ISOLATING LEVER 1000V

OE 0760

1000V insulated disassembly lever. Allows the removal of sensitive parts on electric vehicles. Avoids damage to parts that mark easily (e.g. plastic trim or covers)



Specifications:

- 1000 V insulated tool
- electrical standard : CEI 60900 1000V AC , 1500V DC
- total length : 190 mm

1000V **NO WARRANTY** **TN**

INSULATED RESCUE ROD L.147cm

OE 0720

For the rescue of agents affected by electrification and/or dazzle when repairing a voltage tester for example. Allows the injured party to be brought to safety by pulling them by the waist.

Specifications:

- operating voltage: 45,000V
- steel hook 18x1,5mm
- tensile force: 150kg

Compatible with authorizations: B1L, B1VL, B1TL, B2L, B2VL, B2TL, BCL, BEL, BRL, B1XL, B2XL.

Supplied with wall hooks.



NO WARRANTY **TN**

SAFETY STEERING WHEEL COVER

EG 0031

Allows you to lock the steering wheel of vehicles subject to inspection.



Specifications:

- diameter: 400mm

NO WARRANTY **TN**

LOCKING OUT BAG

OE 0562

Allows to lock the plugs and connectors. To be done by the authorized technician. Lockable with a padlock.



Specifications:

- nylon bag
- dimensions L.482x1.165mm

Must be used with the locking padlock (OE0564).

2 WARRANTY **TN**

LOCKING DISC

OE 0563

Hole of 10mm of diameter on the upper part allowing to receive a padlock.



Specifications:

- Plastic disc
- Diameter: 80mm

Must be used with the locking padlock (OE0564).

NO WARRANTY **TN**

LOCKING PADLOCK

OE 0564



Specifications:

- color: Orange
- handle material: Composite
- inside height of handle: 38mm
- handle diameter: 4.5mm

2 WARRANTY **TN**

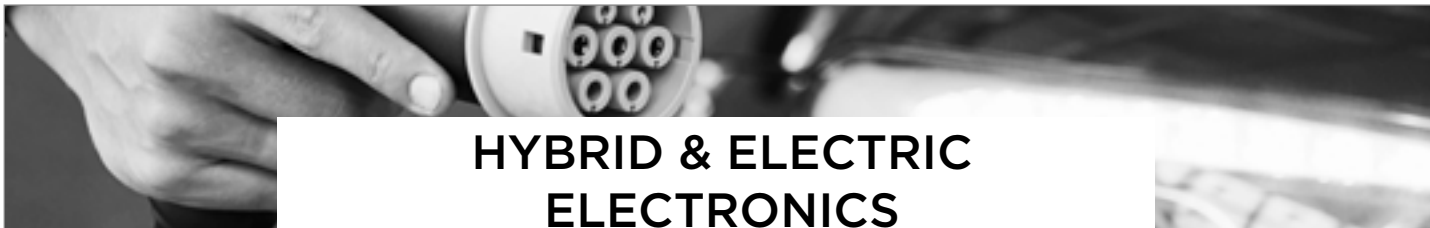

HYBRID & ELECTRIC ELECTRONICS

HYBRID AND ELECTRIC VEHICLES INTERVENTION SET

TN

OE 0355



OE 3010



OE 0844



OE 0840



OE 0755

Contents:

- OE3010: VAT safety tester
- OE0840: 1000V insulated tool set for hybrid and electric vehicles (27pcs)
- OE0844 (x4) : insulated fixing pliers
- OE0874 : insulated universal pliers

HYBRID AND ELECTRIC VEHICLES INTERVENTION MASTER SET

TN

OE 0365



OE 4002



OE 3010



OE 0840



OE 0755

Contents:

- OE3010: VAT safety tester
- OE0755: 3/10th insulating sheet 12.5x1.3m
- OE4002: megohmmeter 1000V CAT. III & 600V CAT. IV
- OE0840: 1000V insulated tool set for hybrid and electric vehicles (27pcs)
- OE0844 (x4): insulated mounting clamp
- OE0845: 4 insulating caps Ø10mm
- OE0846: 4 insulating caps Ø20mm
- OE0847: 4 insulating caps Ø30mm
- OE0848: 4 insulating caps Ø60mm



OE 0844





1000V INSULATED TOOL SET FOR HYBRID AND ELECTRIC VEHICLES (27PCS)

OE 0840

This kit is designed for maintenance and repair work on electric and hybrid vehicles.

All tools comply with IEC 60900 standards, to guarantee safety during work.

NEW



See all our retail items



Standard: IEC 60900

Contents:

- OE0834: 7mm 1000V 3/8" insulated socket
- OE0821: 8mm socket 1000V 3/8" insulated
- OE0822: 10mm socket 1000V 3/8" insulated
- OE0824: 12mm socket 1000V 3/8" insulated
- OE0825: 13mm socket 1000V 3/8" insulated
- OE0826: 14mm socket 1000V 3/8" insulated
- OE0835: 15mm socket 1000V 3/8" insulated
- OE0828: 17mm socket 1000V 3/8" insulated
- OE0830: 19mm socket 1000V 3/8" insulated
- OE0832: 22mm socket 1000V 3/8" insulated
- OE0837: 1000V 3/8" insulated ratchet
- OE0838: 1000V 3/8" insulated extension cord
- OE0839: 1000V 3/8" insulated T-handle
- OE0836: 1000V insulated knife
- OE0886: 1000V insulated 4x100 slotted screwdriver
- OE0887: slot screwdriver 5.5x125 insulated 1000V
- OE0881: Phillips screwdriver 1x80 insulated 1000V
- OE0882: Phillips screwdriver 2x100 insulated 1000V
- OE0685: 7mm open-end wrench, 1000V insulated
- OE0686: wrench 8mm insulated 1000V
- OE0688: 10mm wrench 1000V insulated
- OE0690: 12mm insulated flat wrench 1000V
- OE0691: wrench 13mm insulated 1000V
- OE0692: wrench 14mm insulated 1000V
- OE0695: wrench 17mm insulated 1000V
- OE0874: 1000V insulated universal pliers
- OE0873: 1000V insulated cutting pliers
- case with foam





TN

VOLTAGE SAFETY TESTER

OE 3010

Essential for the building industry or electric vehicles, the VAT tester allows to check the absence of voltage on a circuit before starting work in accordance with the NF C18-510 and IEC 61243-3VAT/DDT standards.

+ Complies standard NF C18-510 and IEC 61243-3VAT/DDT

Specifications:

- continuity test
- differential circuit breaker test 30mA
- moisture and dust proof
- voltage test: 2 at 690V AC/DC and 750V DC with noise emission for range change
- auto AC/DC
- resistance measurements until 2kΩ
- continuity noise test until 2kΩ
- frequency of use: DC 50-60Hz and 400Hz
- self-test of probes, cords, displays, 9V battery
- low impedance output: 390kΩ
- probes center distance: 19mm (for circuit breakers)



Compatible empowerment: B1L, B1VL, B1TL, B2L, B2VL, B2TL, BCL, BEL, BRL, B1XL, B2XL.



BLACK TOUCH POINT IP2X FOR VAT DEVICE

OE 3011

RED TOUCH POINT IP2X FOR VAT DEVICE

OE 3012

Accessory of OE 3010

IP2X measuring tip with 4 mm female banana coupling, black. Hard tip to scrape varnish, paint, oxidation. Safety 1000 V CAT IV

Standard: IEC 61010-031



TN



MEGOHMMETER 1000V CAT. III & 600V CAT. IV

OE 4002

Specially designed for hybrid and electric vehicles, this device can measure the isolation of electrical equipment, as well as a voltage up to 1000V.

It allows the measurement of DC and AC voltage, DC and AC current, temperature, resistance, capacity, isolation and frequency.

Contents:

- 1x Megohmmeter
- 1x pair of measuring cables
- 1x pair of crocodile clips
- 1x MS 3204
- 1x temperature probe (Thermocouple type K)
- 1x transport house
- 1x transport strap (shoulder strap)
- 4x LR6 batteries

Suitable for the "low voltage" requirements of authorisations: BCL, B2VL, B2TL, B2XL ...



TN





INSULATED TOOLS

TN

1/4"

NEW

INSULATED RATCHET AND SOCKET INSERT 1/4" (46 PCS)

OE 0660

EN/IEC 60900

Contents:

- OE0661: 1/4" 4mm insulated socket
- OE0662: 1/4" 5mm insulated socket
- OE0663: 1/4" 5.5mm insulated socket
- OE0664 : 1/4" 6mm insulated socket
- OE0665 : 1/4" 7mm insulated socket
- OE0666 : 1/4" 8mm insulated socket
- OE0667 : 1/4" 9mm insulated socket
- OE0668 : 1/4" 10mm insulated socket
- OE0669 : 1/4" 11mm insulated socket
- OE0670 : 1/4" 12mm insulated socket
- OE0671 : 1/4" insulated socket 13mm
- OE0672 : 1/4" insulated socket 14mm
- OE0673 : 1/4" insulated socket h3
- OE0674 : 1/4" insulated socket h4
- OE0675 : 1/4" insulated socket h5
- OE0676 : 1/4" insulated socket h6
- OE0677 : 1/4" insulated socket h8
- OE0678 : insulated extension 1/4" 75mm
- OE0679 : insulated extension 1/4" 150mm
- OE0680 : 1/4" insulated ratchet
- OE0681 : 1/4" insulated nozzle holder
- OE0682 : 1/4" insulated nozzle screwdriver holder
- 24 nozzles



Insert dimensions:
390x190x35mm



3/8"

NEW

INSULATED RATCHET AND SOCKET INSERT 3/8" (14 PCS)

OE 0820

EN/IEC 60900

Contents:

- OE0821: 3/8" 8mm insulated socket
- OE0822: 3/8" 10mm insulated socket
- OE0823: 3/8" 11mm insulated socket
- OE0824: insulated socket 3/8" 12mm
- OE0825: insulated socket 3/8" 13mm
- OE0826: insulated socket 3/8" 14mm
- OE0827: insulated socket 3/8" 16mm
- OE0828: insulated socket 3/8" 17mm
- OE0829: insulated socket 3/8" 18mm
- OE0830: insulated socket 3/8" 19mm
- OE0831: insulated socket 3/8" 21mm
- OE0832: insulated socket 3/8" 22mm
- OE0837: 3/8" insulated ratchet
- OE0838: 3/8" insulated extension 150mm
- OE0839: 3/8" insulated t-handle



Insert dimensions:
390x190x35mm





TN

INSULATED OPEN END WRENCH INSERT (15 PCS)

OE 0683

EN/IEC 60900

NEW



Contents:

- OE0684: 6mm insulated flat wrench
- OE0685: 7mm insulated open-end wrench
- OE0686: 8mm insulated open-end wrench
- OE0687: 9mm insulated flat wrench
- OE0688: 10mm insulated flat wrench
- OE0689: 11mm insulated flat wrench
- OE0690: 12mm insulated flat wrench
- OE0691: 13mm insulated flat wrench
- OE0692: 14mm insulated flat wrench
- OE0693: 15mm insulated flat wrench
- OE0694: 16mm insulated flat wrench
- OE0695: 17mm insulated flat wrench
- OE0696: 18mm insulated flat wrench
- OE0697: 19mm insulated flat wrench
- OE0698: 21mm insulated flat wrench



Insert dimensions:
390x190x35mm



INSULATED OFFSET RING SPANNER DOUBLE HEX INSERT (11 PCS)

OE 0850

EN/IEC 60900

Tested to 10000V, approved to 1000V

NEW



Contents:

- OE0851: 12-pin 8mm insulated socket
- OE0852: 12-pin 10mm insulated socket
- OE0853: insulated socket double hex 11mm
- OE0854: insulated socket double hex 12mm
- OE0855: insulated socket double hex 13mm
- OE0856: insulated socket double hex 14mm
- OE0857: insulated socket double hex 15mm
- OE0858: insulated socket double hex 16mm
- OE0859: insulated socket double hex 17mm
- OE0860: insulated socket 12 hex 18mm
- OE0861: insulated socket double hex 19mm



Insert dimensions:
390x190x35mm



TN



INSULATED CLAMPS INSERT (4 PCS)

OE 0870

EN/IEC 60900
Tested at 10000V, approved at 1000V



INSULATED
ADJUSTABLE
PLIERS

OE 0871



INSULATED
PLIERS WITH
HALF ROUND

OE 0872



INSULATED
PLIERS SIDE
CUTTER

OE 0873



INSULATED
UNIVERSAL
PLIERS

OE 0874

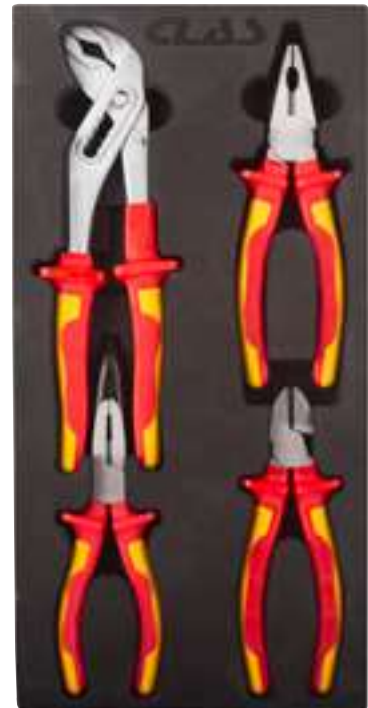

Dimensions insert :
390x190x35mm

Contents:

- OE0871: insulated multi-socket pliers
- OE0872: insulated half-round bent nose pliers
- OE0873: insulated diagonal cutting pliers
- OE0874: insulated universal pliers



INSULATED SCREWDRIVER INSERT (7 PCS)

OE 0880

EN/IEC 60900
Tested to 10000V, approved to 1000V
Chrome vanadium S2



Dimensions insert :
390x190x35mm

Contents:

- OE0881: insulated Phillips screwdriver PH1x80
- OE0882: insulated Phillips screwdriver PH2x100
- OE0883: insulated Phillips screwdriver PH3x150
- OE0884: insulated Phillips screwdriver PZ2x100
- OE0885: insulated slot screwdriver 2.5x75
- OE0886: insulated slot screwdriver 4.0x100
- OE0887: insulated slot screwdriver 5.5x125





1/4"

INSULATED FLEXIBLE MAGNET

TN

OE 0843

1000 V insulated tool, 440 mm articulated magnet, retrieves screws or nuts up to 120g

NEW



EN/IEC 60900
Tested to 10000V, approved to 1000V



INSULATED TORQUE WRENCH 1/4" 5-25Nm

TN

OE 0841

This tool is specifically designed for use on electric or hybrid vehicles. To ensure optimum use, the insulation is as thin as possible, while guaranteeing a secure grip and good adhesion with gloves. It features a double layer of insulation in 2 different colors, so you can tell at a glance if the insulation is damaged and therefore unusable. Electrically insulated, it is tested to 10000 V and approved to 1000 V AC.

NEW

+ Delivered with calibration certificate



EN/IEC 60900
Tested to 10000V, approved to 1000V



INSULATED TORQUE WRENCH 3/8" 10-50Nm

TN

OE 0842

This tool is specifically designed for use on electric or hybrid vehicles. To ensure optimum use, the insulation is as thin as possible, while guaranteeing good grip and adherence with gloves. It features a double layer of insulation in 2 different colors, so you can tell at a glance if the insulation is damaged and therefore unusable. Electrically insulated, it is tested to 10000 V and approved to 1000 V AC.

NEW

+ Delivered with calibration certificate



EN/IEC 60900
Tested to 10000V, approved to 1000V



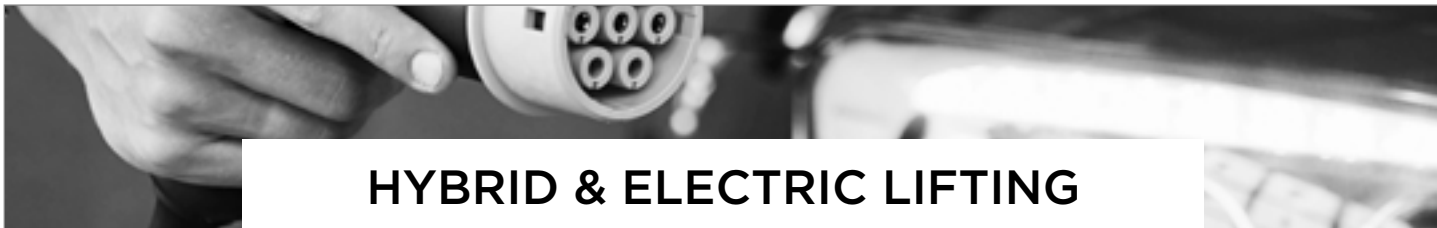

HYBRID & ELECTRIC LIFTING

LIFTING TABLE 1500kg FOR EV BATTERY AND HEAVY ORGANS

OH 1500

This table is specially designed for the removal and support of heavy parts not exceeding 1.5T max load, such as a battery of electric vehicles or a powertrain. Versatile, it will adapt to all your needs thanks to its many settings and optional supports on request. Due to its robust design, it has been designed to meet the needs of intensive use.



STATIC TABLE - PERSONAL SAFETY



+ High load 1500Kg
High precision of settings

Specifications:

- h. min.: 580mm
- h. max.: 1800mm
- max. height on safety catches: 1740mm
- rise time (depending on the load) : 70-110 sec (example: 73 seconds with a load of 457 kg)
- lowering time (depending on the load): +- 30 sec (example: 34 seconds with a load of 457 kg)
- platform length: 1400-1600mm
- platform width: 800mm

- overall length of telescopic frame: 1650mm to 1850mm
- equipped with two wheels made of aluminium and polyurethane : 2 fixed and 2 swivel with brake
- PU wheels
- max hydraulic pressure : 190bar
- pneumatic supply : 6-8bar
- weight : 430kg





A pneumatic control system allows effortless, fast and precise control of the height. The safety is ensured by a system of pneumatically operated side racks.

The plate unfolds for a maximum surface of 1440-1640mmx800mm, and is tapped M10x1.5 to receive various accessories allowing the removal of organs. With the help of 2 screws driven by a 17mm hexagon, it is possible to act on the flatness of the table +/- 5%, and laterally +/- 3,5cm, for a great precision of positioning.

The telescopic frame of the table from 1650mm to 1850mm allows the reception of very large batteries.

Two lateral reservations under the frame of 170mm wide spaced of 750mm, allow the transport of the table with a forklift.

OPERATING TABLE - PERSONAL SAFETY



ADAPTS TO ALL LIFT AND PERSONNEL HEIGHTS

DOWNHILL SAFETY

- controlled descent speed > pressure regulator
- handle support retraction system



UNIVERSAL TABLE

- adapts to all battery types

1 INCLINATION
Inclination adjustment +/- 5%



2 TRAVEL ADJUSTMENT
Table travel adjustment +/- 3.5cm



3 DEPTH
Dept adjustment +/- 20cm



1.5T **2** WARRANTY

TO CONSIDER!

SET OF 12 ADJUSTABLE ROUND RUBBER FOR LIFT TABLE 50mm

CO 1160

Accessory of OH 1201/ OH 1500



SET OF 6 ADAPTABLE SUPPORTS FOR EV BATTERY LIFT TABLE

CO 1161

Accessory of OH 1201/ OH 1500



INSULATING SHEET 3/10TH 12.5X1.3M

OE 0755





★ TOP PRODUCT

LIFTING TABLE 1200kg FOR EV BATTERY AND HEAVY ORGANS

NEW



OH 1201

This table is specially designed for the removal and re-installation of heavy components with a maximum load of 1T (electric vehicle battery and/or drive train).

Versatile, it will be able to adapt to all your needs thanks to its many adjustments and its optional supports on request.

A hydropneumatic control allows effortless, fast and precise height control.

The descent is secured by the "dead man" function which requires 2 simultaneous actions of the operator. This function will be automatically stopped in case of problem concerning the operator. The platform is fully mobile in relation to its frame and has 96 M10x1.5 drilled and tapped points, which can be used to receive various accessories (available on request).

+ Precision and maneuverability

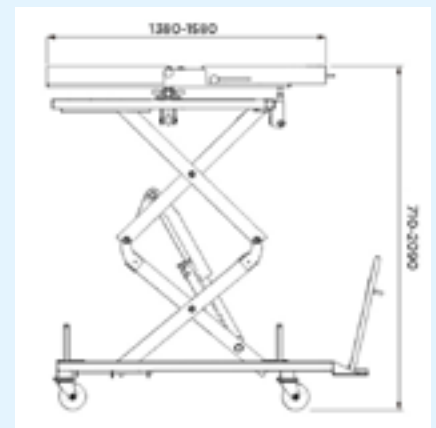
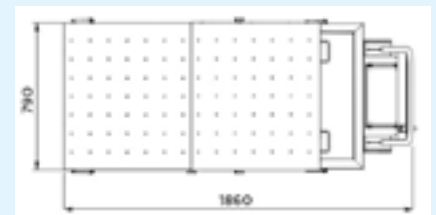

OPTIONS

TN

SET OF 12 ADJUSTABLE ROUND RUBBER FOR LIFT TABLE 50mm

CO 1160

Accessory of OH 1201/
OH 1500



SET OF 6 ADAPTABLE SUPPORTS FOR EV BATTERY LIFT TABLE

CO 1161

Accessory of OH 1201/
OH 1500



x6

Specifications:

- length: 1860mm
- width: 790mm
- minimum table height: 810mm
- maximum tray height: 2090mm
- minimum tray length: 1380mm
- maximum platter length: 1580mm
- rise time: +/-50s
- lowering time: +/-30s
- 4 swivelling braked wheels: 130mm
- 4 handles placed around the table for optimum comfort of use when adjusting the load at rest.

Adjustments:

- the table top unfolds into three lockable positions for a maximum surface area of 1560mmx730mm. It is t+I30apped M10x1.5 to accommodate various accessories (available on request).
- the table's flatness can be adjusted at 2 points for high positioning accuracy
- the table top can be moved in translation and pivoted for greater precision when repositioning elements.



1.2T





TN

1.5T CHARGE BALANCER FOR VEH BATTERIES

OH 0260

This tool is an indispensable aid for moving and handling electric vehicle batteries. Its four straps ensure load stability by distributing the weight.



Maximum load capacity: 1.5T

Contents:

- 1 main bar
- 2 crossbars
- 4 straps with eyebolts at each end
- 1 top hook for lifting



1.5T



MOBILE CRANE 1T

OH 1001

TN

+ European pallet format

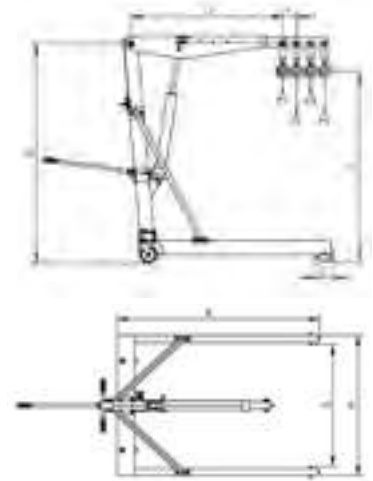

Specifications:

- 4-position arm: 1000-900-800-700kg
- double-acting pump
- weight: 92kg



1T



PAD FIAT 500E/500X/JEEP RENEGADE Ø100 X H.55

EG 1154

TN



TESLA PAD 3 Ø76/26 x h.51/25

EG 1153

TN



TO CONSIDER!

2 COLUMNS POST LIFT HIGH PASSAGE 3.90m 400V 6T 4 ARTICULATED ARMS

PE 2339T

Particularly adapted to repair activities on extended utility vehicles, 4x4, micro car.
Electro-hydraulic post lift.
Pusher cylinder direct on carriage.
Arms with adjustable joints.
Hose and cable routing from the top for optimum working comfort, allowing free access to equipment under the vehicle (cylinders, oil recuperator, battery removal, etc.), facilitating workshop cleaning.
Hydraulic power pack: equipped with a position safety device for precise intervention, gearbox assembly, nut alignment, etc.
Multiple lifting capacities thanks to 4 multi-adjustable articulated arms.
Cylinder and cable protection strip included on each column.



TE

NEW

6T

2 WARRANTY



PAIR OF UNDER-WHEEL EXTENSIONS

PE 2114

Adaptable to post lifts:

- PE 2105T post lift low passage 4 arms 1500mm
- PE 2106T post lift low passage 4 arms 1800mm
- PE 2238T post lift 3,8m high passage arms 1500mm
- PE 2240T post lift 3,8m high passage arms 1800mm
- PE 2245T post lift 4,5m high passage arms 1800mm
- PE 2250T post lift 5,0m high passage arms 1800mm

Adaptable to arms :

- PE 2111
- PE 2115

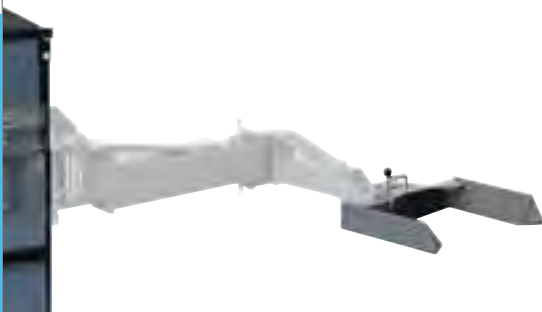

NEW



TE

2 WARRANTY

ELECTRIC BRAKE AND CLUTCH BLEEDER 5L 2.5bar

HU 1101

Compact and lightweight.
Automatic stop when the level in the can is too low.
Automatic bleeding after canister change.
Checks the low pressure brake system for leaks.



TN

COOLING SYSTEM FILLING/DRAINING DEVICE

AC 1020

Specifications:

- 2 independent 15-liter tanks for storing polluted and new liquid
- 2 manometers for tank control
- connection to the expansion tank via a conical adapter
- 3 dip tubes of different lengths
- 4 swivel wheels
- dimension: L.430xI.610xH.1350mm
- weight: 43kg

Functions:

- used liquid extraction
- depression
- new liquid filling
- emptying used liquid tank
- emptying new liquid tank



TN

2 WARRANTY



3 WARRANTY





TE

10" THINKCAR CE EVD DIAGNOSTIC TOOL

AD000CEEVD

VEH

THINKTOOL CE EVD is a new generation of intelligent diagnostic tool for electric vehicles, the CE EVD provides complete system and battery pack diagnostics for over 74 commonly used electric vehicle brands, including Tesla.

CE EVD is equipped with a powerful THINKDIAG 4 VCI 3-in-1, which can be run via the battery module's OBD.

Supplied with:

- T-WAND 200 (AD000TKTG3)
- printer
- 18 high-voltage battery connectors

NEW

+ 2 years of free updates

AD000TKTP2 AD000TKTG3



CAN protocol	CAN ^{FD} protocol	DOIP protocol	J2534 protocol	35 functions see p.76	Manufacturer-level diagnostics	Online programming	Remote control	TPMS service	+80 EV brands
				Battery pack diagnostics	Secure Gateway	HaynesPro			

Available for sale only in France and French overseas departments and territories.

10"	Android 10	CPU 2.0GHz 4 core	128 Go	8 Go RAM	12600 mAh	8M back



2 WARRANTY

THERMAL IMAGER

AD000TKTR1

NEW

Accessory of AD000TKX16/ADTKT04EMX/ADTKT05EM/ADTKT03EMSE/ADTKT03EML/AD00TKT02L/AD000TK900/ADTKTEURO195



Specifications:

- 320x240 ultra-high pixels, easy-to-see details
- 0 to 530° (0.07°C) thermal sensitivity
- thermal database for defect comparison

Available for sale only in France and French overseas departments and territories.

2 WARRANTY



THINKCAR EVP802 BATTERY PACK MODULAR EQUALIZER

AD00EVP802

Used to optimize battery performance in electric vehicles and extend battery life. Its function is to balance the cells in a module (2 X 12 cells via 2 channels, i.e. 2 modules simultaneously). It is able to charge some cells, while discharging others, in order to obtain the target cell voltage. The charge/discharge current is 5A and 2.5A for balancing. A report can be extracted at the end of the cycle.

NEW



Specifications :

- power supply: 90-260V (40-60Hz)
- charge/discharge voltage range: 1.8 - 4.2V
- voltage detection accuracy: +/- 2mV (Max 5V)
- charge/discharge current range: 0.1 - 5A
- actual charge accuracy: +/- 0.05A (Max 5A)
- battery temperature detection accuracy: +/- 2°.
- modules supported: 2 modules (1 module with max. 12 batteries)
- charge/discharge power: max 600W
- battery interface: 16-pin/24-pin
- display: 7" screen
- communication: via TCP/IP, USB device
- charge/discharge data: Histogram / Data table
- size: 496x246x262mm
- weight: 14 Kg

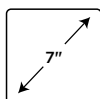



HYBRID & ELECTRIC CHARGING

CHARGING CABLE T2-T2 7.2kW 5m

OE 2041

Charging cable, 16A, 1 phase, 7.2kw for electric vehicle. Type 2 (IEC 62196-2) female and male plug, length 5m.

Specifications:

- 7.2KW
- 16 A
- 1 phase
- length : 5m
- plug : type 2



7.2kW



TN

CHARGING CABLE T2-T2 22kW 5m

OE 2043

Charging cable, 32A, 3 phases, 22kw for electric vehicle. Type 2 (IEC 62196-2) female and male plug, length 5m.

Specifications:

- 22KW
- 32 A
- 3 phases
- length : 5m
- plug : type 2



22kW



TN

PORTABLE EV CHARGER T2 3.6kW 5m

OE 2046



Specifications:

- IP66: waterproof and dustproof
- IK 10: withstands the impact of a 5kg weight dropped from 40cm.
- sockets: type 2 & type E
- max output current: 16 A.
- switchable current: 10 A, 13 A and 16 A.
- total length: 5M (3.5M type 2 + 1.5M type E)
- interchangeable waterproof cap





CHARGING STATION 11kW REEL 6m T2

OE 2047

plug-and-play charging unit.
For both private and public use.
For your installation requirements, please do not hesitate to contact us.

This station offers:

- elegant and compact design
- simplified operation
- digital display showing essential information: charging power, current in real time, charging time and charging capacity



+ Easy to use

Specifications:

- digital touchscreen
- height: 437mm
- width: 217mm
- thickness: 74mm
- IP66
- H07BZ5-F cable
- standard EN 61851-1

Contents:

- 11kW terminal block
- 6m cable with TS plug
- One wall hook

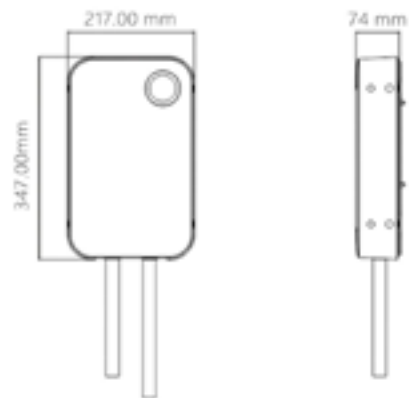

ADVANTAGES

- Protection against :
- circuit overcurrents
 - leakage circuits
 - earth leakage
 - overheating
 - thunder protection

NOTE

Installation requires IRVE-approved electrician
Panel protection not supplied:
- 25A type A or B differential switch
- 20A C-curve 10kA circuit breaker



11kW

