

2024 - 2025

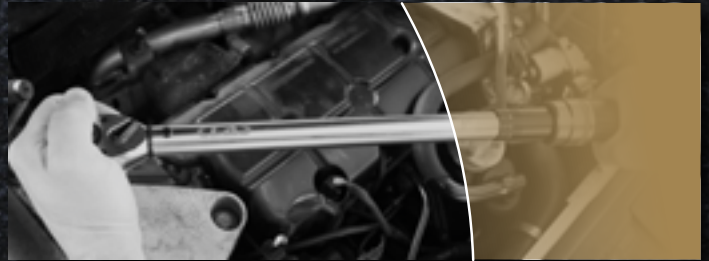

**CLAS**<sup>®</sup>  
GLOBAL GARAGE SOLUTIONS

*Solutions*  
**GENERAL  
TOOLS**





# 89

## GENERAL TOOLS

Browse through our GENERAL TOOLS solutions, from our 24-25 general catalog.



**90** - LIGHTING



**100** - FLUID DISTRIBUTION & GREASING



**105** - CLEANING



**111** - REELS



**116** - PNEUMATIC TOOLS



**133** - PORTABLE POWER TOOLS

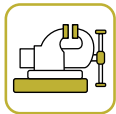

**140** - WORKSHOP DEVICE



**154** - DRILLING & THREADING



**158** - LIFTING



**181** - PRESS SHOP

You can find our full range on [clas.com](https://www.clas.com) (or in our general catalog)



# CHOOSE YOUR INSPECTION LAMP PROPERLY.

## Why?

Eye strain is usually not considered during work, but its impact can be quickly disabling.

Excessive light intensity may cause annoyance (reflection, dazzling, straining).

A race towards intensity? Yes, but not only.

Your choice should also be influenced by:

- Environment of the intervention (indoor/outdoor, passenger cabin, engine compartment...)
- Size
- Frequency of use
- Shock resistance

## EXPERT ADVICE

Choose a variable intensity light (autonomy management, work comfort).

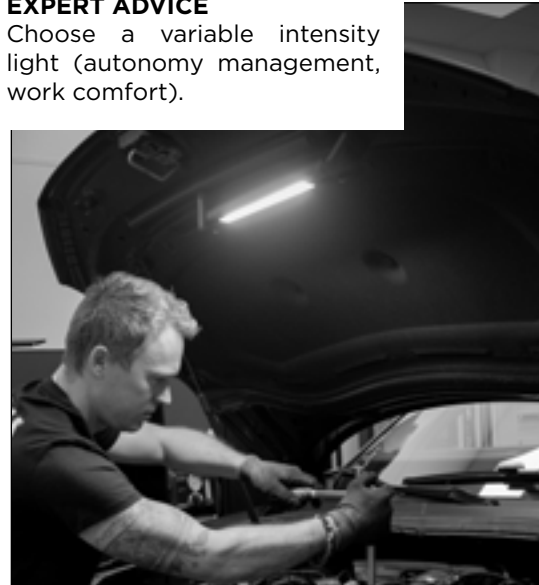
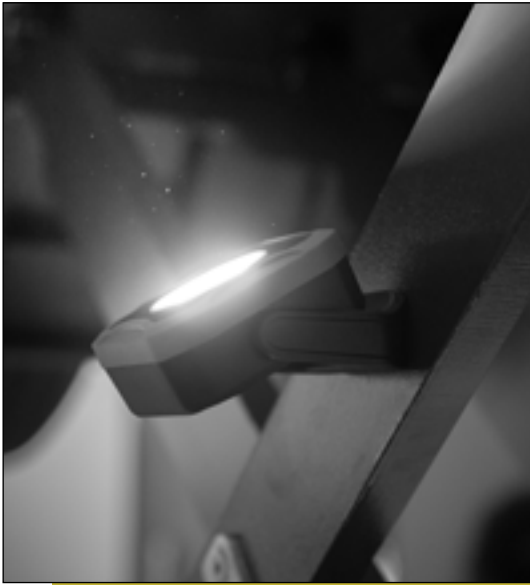

## THERE ARE 4 MAJOR LAMP CATEGORIES



### HEADLAMP

- + Hands-free lighting, hard- to-reach areas, perfect for cabin operations
- Uncomfortable headband when wearing it a long time



### PENLIGHT

- + Fast inspection, always in the pocket
- Low intensity



### INSPECTION LAMPS

- + Versatility, strong, autonomy, perfect for an extended use
- Space saving



### RAMP

- + Hands-free lighting, wide range of lighting, telescopic, optimum visual comfort, perfect for cabin interventions
- Space saving



**KELVIN**

It is the color temperature scale, which describes the way certain colors appear to us visually. We refer to warm or cool white depending on the number of Kelvin. Lamps between 5000 and 7000K are those that are close to daylight.

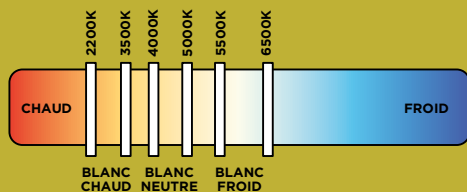

**WHAT IS "LUMEN"?**

It is the unit of luminous flow measurement, meaning the power of your lighting. One Watt is equivalent to +/- 80 Lumens (depending on the type of LED used).

**PROTECTION RATINGS**



**IP:** protection rating against liquids and dust. 1st number: from 0 to 6 indicates protection against solid bodies. 2nd number: from 0 to 8 indicates protection against liquids. The higher the number, the more the product is liquid tight and/or dust-tight.



**IK:** protection rating against shocks and impacts. This number goes from 01 to 10. The higher the index, the more resistant the product is. Going from 06 to 08 means a product 5x more resistant.

**COMPARATIVE OVERVIEW**

		LUMEN MAX	IK	6H	3H	VARIATOR	IP	HEAD LIGHT	ROTATION	FIXATION	<b>THE ADVANTAGES</b>
<b>HEADLAMP</b>	OE 0199BL 	400lm	IK07	3h à 8h	4h	no	IP43	yes	-	elastic band	<b>Wide light angle</b>
<b>INSPECTION LAMPS</b>	OE 0299 	500lm	IK07	1h30 à 8h	3h	no	IP55	yes (500lm)	-	magnet + clip-on pocket	<b>Pocket size to always have it on hand</b>
	OE 0145BL 	600lm	IK04	2h à 10h	4h	yes	IPX3	no	360°	magnet + hook	<b>Economical</b>
	OE 0143 OE 0143R 	600lm	IK07	2h à 16h	4h	yes	IP54	yes (90lm)	360°	magnet + hook	<b>Ultra thin</b>
	OE 0099BL 	450lm	IK05	5h à 15h	3h	no	IP33	no	180°	magnet + clip-on pocket	<b>Multipurpose</b>
	OE 0399 	360lm	IK07	3,5h à 8h	4h	yes	IP54	no	-	magnet + hook	<b>Ultra thin</b>
<b>FLOOD LIGHTS</b>	OE 0499 	1000lm	IK07	7h	4h	no	IP54	no	360°	magnet	<b>4000mAh high-capacity battery</b>
<b>RAMPS</b>	OE 0179 	1200lm	IK07	2h à 6h	4,5h	no	IP52	no	360°	crochets anti-scratch	<b>180° light diffusion</b>
	OE 0899 	1200lm	IK07	2h à 15h	4,5h	yes	IP44	no	360°	magnet + hook	<b>Ultra powerful</b>
<b>UV</b>	OE 0699 	-	IK07	5h	4h	no	IP66	no	180°	magnet + hook	<b>UV lighting</b>





# HEADLAMPS

TN

## DOUBLE HEADBAND HEADLAMP

OE 0199BL

The stretch + silicone headband adapts to all head sizes and provides comfort during use. Dual COB LED headband for improved light output and diffusion. Its contactless sensor makes it easy to switch on and off, even with dirty hands.

400 LM



50 LM

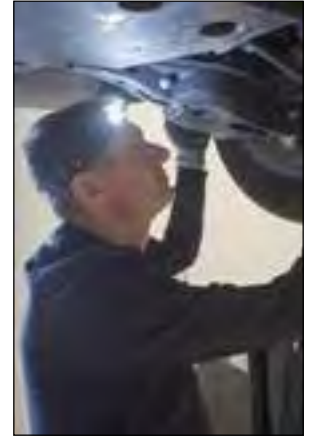

**B.LINE**  
BUDGET SOLUTION

**+** Light and powerful

**NEW**

Hands-free sensor



2 MODES  
100%/50%

2 MODES  
100%/50%

Stretch and silicone headband



Practical: with its motion sensor, it can be switched on and off with no hands!



Available in sets of 12 (delivered in display)

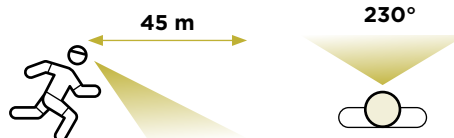



# INSPECTION LAMPS

## MINI HAND LAMP

OE 0299

Powerful, double-lit, IK07 aluminum body, all in a compact size. It's within easy reach at all times.

TN

**+** Pen format, fits in your pocket!

**NEW**



Overhead lighting

**2 MODES**  
100%/50%

Fluorescent when lamp is off

Pocket clip

Aluminum body



97 mm

500 Lumens in a small package!





# WORKSHOP HAND LAMP

OE 0099BL

Compact size, ABS body, articulated, magnetic and double-lit: the ideal companion for your operations.

**B.LINE**  
BUDGET SOLUTION

**NEW**



Overhead lighting



Pocket clip and hook



2 MODES  
100%/50%



164 mm

Available in sets of 12  
(delivered in display)



**+** Multipurpose



- 15
- 3H
- 450 LM  
7000 K
- IK05
- IP 33
- 180°
- USB-C

2 WARRANTY



# EXTRA-FLAT INSPECTION LAMP

OE 0399

Its extreme slimness (10mm) will enable you to work in the tightest spaces without difficulty. Its sturdy design (IK07, aluminum body) makes it both durable and ergonomic.

**NEW**

**+** Ultra-thin! Only 10mm thick

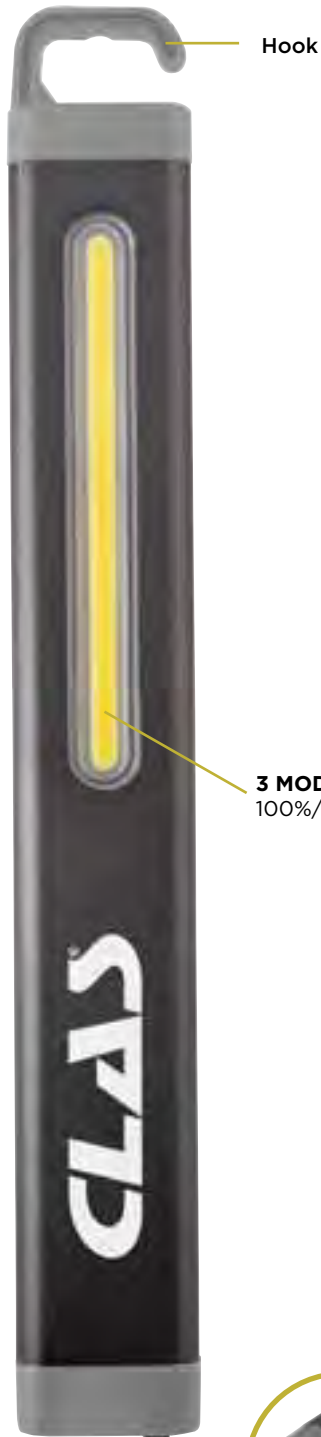

Hook

**3 MODES**  
100%/50%/Flash



Aluminum body



250 mm



10mm



- 8H
- 4H
- 360 LM 6500 K
- IK07
- IP 54
- USB-C

**2** WARRANTY







# ULTRATHIN CORDLESS RECHARGEABLE LAMP WITH VARIABLE INTENSITY

OE 0145BL

**B.LINE**  
BUDGET SOLUTION

**+** Economical

Hand lamp equipped with a dimmer.  
Rechargeable via USB cable provided.

**ADVANTAGE**  
Good quality/price ratio



377 mm





TN

★ TOP PRODUCT

385 mm



● ULTRATHIN CORDLESS RECHARGEABLE LAMP WITH VARIABLE INTENSITY 7W IK07  
 (OE 0143)

● ULTRATHIN CORDLESS RECHARGEABLE LAMP WITH VARIABLE INTENSITY RED  
 (OE 0143R)



+ Precise light intensity



Flash to watch the video!

Lamp equipped with a dimmer, allowing an optimal intensity adjustment in all situations. The headlight can be used alone or simultaneously with the front lighting thanks to the separate switch. Impact-resistant ABS body with rubber coating for perfect grip.

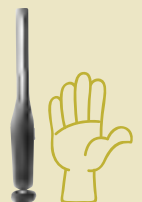



### UV INSPECTION LAMP

OE 0699

Essential for leak detection in conjunction with UV tracers.

Its power will enable you to detect all leaks in your air-conditioning, oil, LR or fuel circuits.



193 mm



**NEW**



180°



**2**  
WARRANTY



## FLOODLIGHTS

### MOBILE SPOTLIGHT COB 1000LUMENS

OE 0499

High lighting power in a small package!

**NEW**

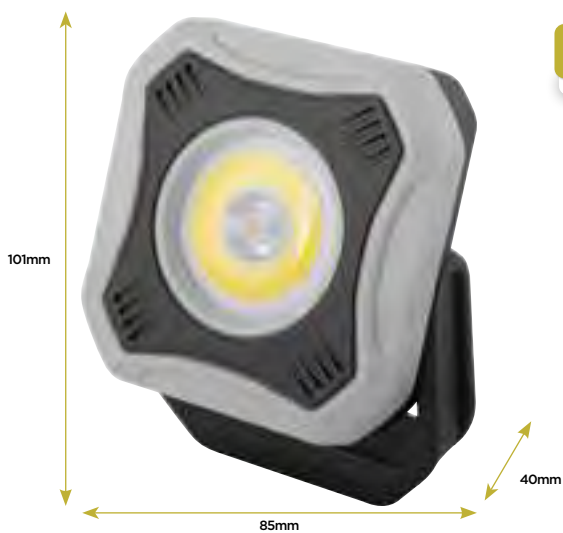

10mm

85mm

40mm

**+** 4000mAh high-capacity battery



180°

Tripod mount + magnet



**2**  
WARRANTY



# RAMPS

## DECK RAMP LAMP

TN

OE 0899

ABS and TPU body: highly resistant to shock and abrasion!

Ideal on deck for powerful (1200Lumens!), targeted light thanks to 360° orientation.



**NEW**

**+** Powerful and optimal adjustment



Double hook



- 15H
- 4.5H
- 1200 LM 6000 K
- IK07
- IP 44
- 360°
- USB-C

2 WARRANTY

## RECHARGEABLE RAMP 1200LUMENS

TN

OE 0179

The light ramp is quick and easy to install, so you can work hands-free under the hood or in the passenger compartment.



**+** Two choices:  
Powerful lighting: 1200Lumens  
Soft lighting: 400Lumens

**NEW**



- 6h
- 4H
- 1200 LM 6500 K
- IK07
- IP 52
- 360°
- USB-C

2 WARRANTY



# TRAY COLLECTORS

## FLUID COLLECTION CONTAINER

TN

HU 0031



### Specifications:

- dimensions: 780x495x120mm
- max. wheelbase: 920mm
- equipped with 4 swiveling wheels
- 2 carry handles
- pouring spout



## HGV AXLE DRAIN PAN

TN

HU 0035

This pan has been designed to collect fluids from HGV axles. When removing a wheel shaft on an industrial vehicle, the oil in the reducers flows onto the rim. This pan has been designed to collect this oil.



- to be placed directly onto the wheel to collect the oil
- suitable for several rim sizes
- with pouring spout

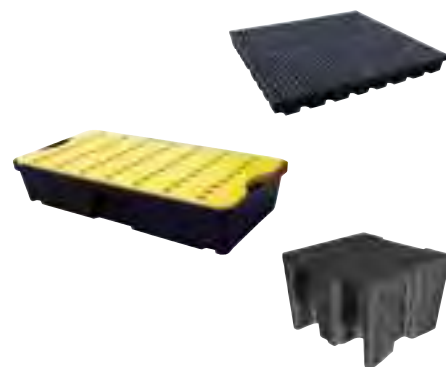

### NOTE

Find out more about our Storage spill containment range p. 67

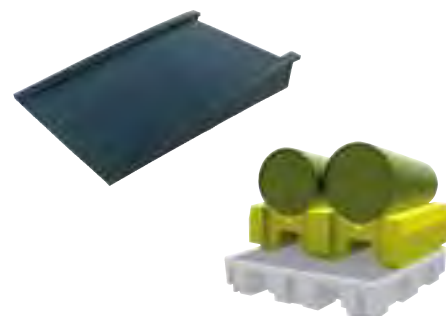



# FLUID DISTRIBUTION

## FLUID EXTRACTOR/DISPENSER

TN

HU 0631

For motor oil, cooling fluid, brake fluid...  
Do not use with flammable liquids



**Specifications:**

- probe length: 1600mmx3
- Ø6-8-10mm
- manual pump
- pressure/vacuum inverter



## FUEL TRANSFER PUMP

TN

HU 0629



Supplied with 130cm transfer hoses



## 0.2l SYRINGE

TN

HU 0637



Graduation



## 1.5l SYRINGE

TN

HU 0638



Graduation





MANUAL PRIMING PUMP WITH TAPPET

HU 0657BL



Manual priming pump, suitable to transfer several kind of liquids (non-corrosive) from a standard 200l drum.



TN

METAL TRANSFER PUMP

HU 0014BL



Pump with a lateral lever, ideal for transferring various types of liquid (non corrosive) such as oil, diesel or kerosene from a standard 200l barrel.



TN

2L GRADUATED PITCHER

HU 0002



TN

5L GRADUATED PITCHER

HU 0005



TN

TRANSFER PUMP FOR DRUMS 200L

HU 0011



Side lever barrel pump suitable for pumping various (non corrosive) liquids such as oil, diesel, anti freeze and washer fluid from standard 200l drums.

Specifications:

- viton® seals
- 3 flow positions: 310/330/350 mL by pumping
- extending tube to reach the bottom of drums
- 2 in 1 fixing: Ø59mm thread 200-Ø63 thread 400



TN

ROTARY PUMP SUITABLE FOR AdBlue®

HU 0013



Special pump to transfer AdBlue. Also suitable for other fluids like water, diesel, oil...



Specifications:

- supplied with a 2" bsp fitting
- 0.3 litre per crank turn
- inlet tube 1000mm
- fixing Ø59mm thread 200



TN



TN

3:1

3:1 PNEUMATIC OIL PUMP

HU 0712

- ratio: 3:1 for low to medium viscosity oil (SAE 15/130)

5:1

5:1 PNEUMATIC OIL PUMP

HU 0713

- ratio: 5:1 for medium to high viscosity oil (SAE 15/240)

Specifications:

- maximum flow rate: 12l/min
- 4m hose included
- supply pressure: 6-8bar
- supplied with barrel adapter



OIL PUMP REGULATOR

HU 0719

Accessory of HU 0712/HU 0713



TN



DRIP STAND FOR OIL GUN

HU 0710

Accessory of HU 0617/HU 0711



TN



1/2" DIGITAL VOLUMETRIC OIL/ANTIFREEZE GUN

HU 0711

This gun ensures simple, fast and measured dispensing. For oil and antifreeze.



TN



DRUM TROLLEY 180-220kg

HU 0714

Accessory of HU 0711/HU 0712/HU 0713/HU 0617/HU 0639N/HU 0619N



TN



Specifications:

- width: 800mm
- depth: 600mm
- height: 860mm
- support plate dimensions: 652x652mm



FLEXIBLE SPOUT FUNNEL Ø145mm

HU 0513BL

Funnel with spout and filter.



**B.LINE**  
BUDGET SOLUTION

Specifications:

- funnel Ø145mm with filter (L.153mm)
- flexible spout L.260mm







# GREASING

## GREASING GUN 500ml

TN

HU 0512

This high pressure grease gun works at 550bar and has an improved plunger for complete grease removal for both cartridge and bulk grease loading.



For 500ml cartridge, supplied with flexible.



## PNEUMATIC GREASING GUN 450ml

TN

OP 0521



**Specifications:**

- nozzle length: 170mm
- capacity: 450ml
- operating pressure: 6.2bar
- weight: 1.8kg



## HOSE GREASING REEL Ø8mm 20m 350bar

TN

HU 1818



**Specifications:**

- epoxy powder coated steel brackets
- stop device every 50cm
- reinforced hose SAE 100R2AT
- hose Øint. 8mm
- length 20m
- max pressure 350bar
- connector 1/4"





# VACUUMS

TN



**+**  
2 engines  
air & water

## DRY AND WET VACUUM CLEANER 2x1000W

EG 0040

**Specifications:**

- stainless steel tank mounted on a 4-wheel dolly
- 2 motors of 1000W each
- 80l tank Ø420mm
- drain on 500mm tank
- pressure: 21kPa
- air flow: 108l/s
- sound level: 73dB
- power supply 230V 4m cable
- power: 2000W
- dimension (lengthxdepthxheight): 540x595x940mm

Included accessories:

- SA0442: thin tip with connector Ø42mm
- SA0443: Ø60mm brush with connector Ø42mm
- Ø42mm handle with accessory connector Ø37mm
- SA0440: 2200mm flexible hose Ø42mm
- SA0444: Ø37mm scraper
- SA0445: Ø37mm brush length 400mm
- SA0441: cloth filter



SA 0446 SPIRAL 4000mm Ø42mm

SA 0045 600mm FRONT BRUSH ASSEMBLY WITH HOSE



## DRY AND WET VACUUM CLEANER 2x1000W + SPIRAL 4m

EG 1040



## DRY AND WET VACUUM CLEANER 2x1000W+FRONT BRUSH ASSEMBLY 600mm

EG 0045

Included accessories:

- SA0442: thin tip with connector Ø42mm
- SA0443: Ø60mm brush with connector Ø42mm
- Ø42mm handle with accessory connector Ø37mm
- SA0440: 2200mm flexible hose Ø42mm
- SA0444: Ø37mm scraper
- SA0445: Ø37mm brush length 400mm
- SA0441: cloth filter
- SA0045: front brush assembly 600mm with hose



## PNEUMATIC PORTABLE VACUUM

EG 0407

Lets you vacuum in hard-to-reach places (plug wells...)



Supplied with 3 bits + 1 extender

TN



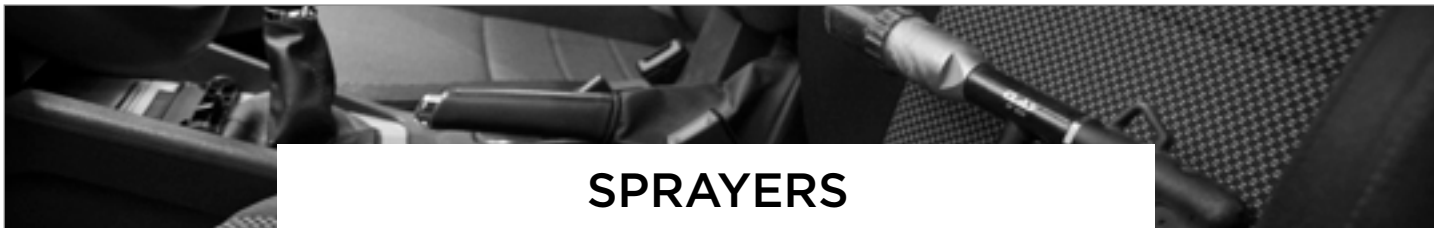

# SPRAYERS

## 1.5L RED PRESSURE SPRAYER

OC 1501



- adjustable nozzle



## 1.5L BLUE PRESSURE SPRAYER

OC 1502



- adjustable nozzle



TN



## PRO SPRAY GUN

OP 0044



### Specifications:

- 2 adjustable jets and air flow
- nozzle L.300mm Ø2mm
- connector 1/4"
- service pressure: 2 to 8bar



TN

## 1.7L PRESSURE SPRAYER BRAKE CLEANER

OC 1510

Wider base for more stability when filling.



Designed for use with brake cleaner



### Specifications:

- Viton® seals
- adjustable nozzle
- capacity: 1.5l+10%
- graduation: 0.5l-16oz
- graduation dilution 5 and 10
- side relief valve
- expanded Base



TN

## HIGH PRESSURE RECHARGEABLE SPRAY 620ml

EG 1532



Ecological

### Specifications:

- trigger release
- aluminum bottle
- 2-in-1 nozzle (mist and jet)
- Schrader®-type pressurization valve
- 12-bar safety valve



TN

## 5L CONTAINER OF BRAKES CLEANER

CO 1530



TN

## DEGREASING/CLEANING PRODUCT FOR WASHERS 25L

CO 1018



TN



# CLEANING GUNS

## ROTATING NOZZLE CLEANING GUN

TN

OP 0025

This blowgun with rotating nozzle has been specially designed for thorough cleaning. removes dirt and dust from carpets, seats, carpets and dashboard. Can be used in the engine compartment.

**+** Rotary flow



## CLEANING GUN

TN

OP 0022



Connector supplied

Cleans bodywork, wheels, dashboard, air vents, engine... and door jamba. Ultra-low consumption thanks to special vortex technology. Its vortex propulsion system gives it unbeatable results.



## CLEANING GUN EVOLUTION

TN

OP 0024

Use it on seats, air vents, gear shift, wheels, ventilation, registration plates, wheel rims... Easy to carry and non-cumbersome

- Encapsulated ball bearing. No rubbing between the bearing and the cone
- reduced wear and tear
  - increased efficiency
  - improved power
  - very fine vaporisation of the liquid for powerful cleaning
  - can be used with a solution of water + cleaning solution or water alone

**Specifications:**

- nozzle rotating speed 4000-8000rpm
- operating pressure 5 to 8 bars
- consumption 180L/min
- bowl capacity 1L
- connector supplied



Flash to watch the video!



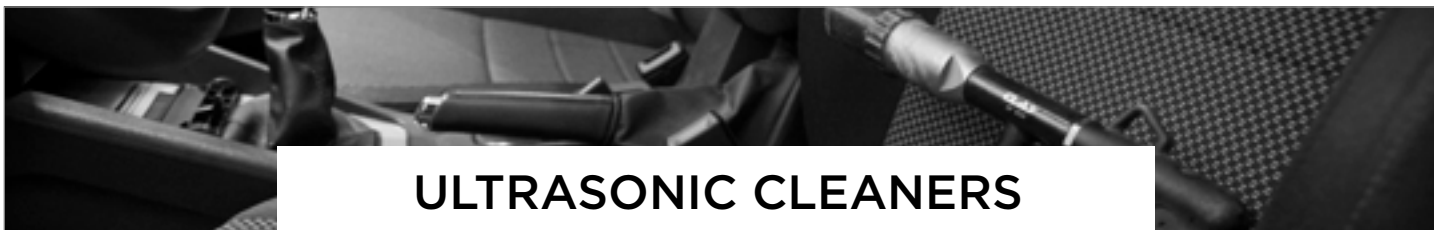

# ULTRASONIC CLEANERS

TN



## ULTRASONIC CLEANER 3I 100W 40KHz

OE 7200

**Specifications:**

- heating temperature adjustable from 0 to 80°C
- timer from 1 to 99 minutes
- ultrasonic power: 100W
- heating power: 100W
- digital display
- tank drain valve
- tank capacity: 3L
- tray dimensions: 240x140x100mm
- external dimensions: 270x240x170mm



## ULTRASONIC CLEANER 9I 200W 40KHz

OE 7201

**Specifications:**

- heating temperature adjustable from 0 to 80°C
- timer from 1 to 99 minutes
- power: 200W
- digital display
- tank drain valve
- tank capacity: 9l
- external dimensions: 330x310x270mm
- tray dimensions: 300x240x150mm



SA 7070 TUB OF ULTRASOUND CLEANING SOLUTION CONCENTRATE 25% 2L

**+** 2L of solution = 8L of product



TN

## WORKSHOP CLEANING WIPES (80 PCS)

CO 0502

Hand cleansing wipes clean without water, soap or rinsing, for occasional or recurrent hand care with maximum effectiveness for all your professional activities.  
Cleans, degreases, removes paint and glue, protects.  
Can be used on all your alloy and plastic tools.  
With Aloe Vera.

**+** Double-sided: soft & rough  
Hypoallergenic and paraben-free



**Specifications:**

- Double-sided: soft & rough
- Removes dirt, grease and grime
- Hypoallergenic and paraben-free
- Protects the epidermis: enriched with Aloe vera
- Citrus fragrance



## CAR CLEANING WIPES (80PCS)

CO 0503

Multi-purpose wipes clean without water or rinsing, for occasional or recurrent maintenance of all vehicles, inside and out.  
The wipes allow you to care for, clean and restore the shine of new in a single operation.  
Cleans, protects, antistatic, water-repellent and high-gloss.  
Can be used on all surfaces such as bodywork, wheels, paintwork, tree resin, interior and exterior plastics, fairings, fairing bubbles, windows, windscreens, optics, chrome, leather and skai upholstery...  
Silicone-free. Compatible with matt bodywork.

**+** Cleans, protects, antistatic, water-repellent, high-gloss



**Specifications:**

- cleanses
- protects
- antistatic
- water-repellent
- high gloss
- biodegradable



## CAR WASH SET (7PCS)

EG 0011BL

This composition is ideal for cleaning not only rims, but also the interior of the passenger compartment.



**ADVANTAGE**  
Compatible avec les perceuses  
PW 2013 et PW 2014



**Contents:**

- 4 soft-bristle brushes: 10-14-16-18mm
- 3 stiff brushes
- 2 flat brushes: 45-120mm
- 1 round-head brush: 85mm

TN



**EXPRESS PAINT REMOVER SPRAY 500ml**

TN

CO 1027

Allows paint, varnish and ink pickling on every body repair painted element.  
Remove burned and imbedded seals (cylinder head, gearbox, water pump, etc).

It allows you to achieve excellent results with no effort required. Its active formula breaks down problems quickly. This product is suitable for use on solvent-resistant mounts.

**Applications:** Acrylic, Glycerol, Alkyd, Pliolite...

Also available in box of 12



**+** Active formula:  
quick and efficient

**BODY REPAIR DEGREASING/CLEANING SPRAY 500ml**

TN

CO 1029

Allows you to degrease and clean bodywork parts before painting or adhesion.  
Eliminates residues of glue, grease, oil, silicone.

Also available in box of 12



**+** Degreases and  
removes silicone  
Antistatic

**CABIN PURIFIERS**

TN

CO 1074	CAR CABIN PURIFIER 400ml <b>LEMON</b>
CO 1075	CAR CABIN PURIFIER 400ml <b>MUSK</b>
CO 1076	CAR CABIN PURIFIER 400ml <b>MINT</b>
CO 6216	CABIN PURIFIER 400ml <b>LAVENDER</b>
CO 6217	CABIN PURIFIER 400ml <b>FOAMING</b>
CO 6218	CABIN PURIFIER 400ml <b>PINE</b>
CO 6220	CABIN PURIFIER 400ml <b>VANILLA</b>

Also available in  
box of 12

**WIRE BRUSH**

TN

EG 0056

Handy steel wire metallic brush ideal for a multitude of uses.

- carbon steel wire
- soft grip handle





# AIR & WATER REELS

AIR REEL Ø8mm 10m

TN

OP 0083BL

Automatic cable distribution during winding

**B.LINE**  
BUDGET SOLUTION

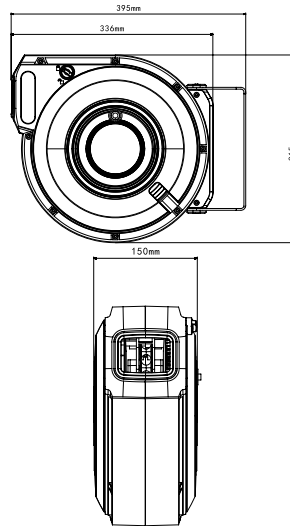

8 mm



**Specifications:**

- pipe: Øint. 8mm - Øext. 12mm, PU (polyurethane)
- resistant PP housing
- cable guide with automatic distribution/sweep
- shut-off device every 50cm (can be deactivated)
- 1/4" connector
- 180° swiveling wall bracket
- operating pressure: 10bar
- high-resistance spring tension



10M **2** WARRANTY

★ **TOP PRODUCT**

TN

AIR REEL Ø10mm 15m

10 mm

OP 1118

**Specifications:**

- hose: Ø int. 10mm, braided PU hose (polyurethane)
- braked winding
- cable guide with automatic distribution/sweeping
- stopping device every 50cm (can be deactivated)
- PP (polypropylene) housing
- 1/4" connection
- 180° swiveling wall bracket
- operating pressure: 10bar



**Automatic cable distribution during winding**

Supplied with fitting. Ready to use!

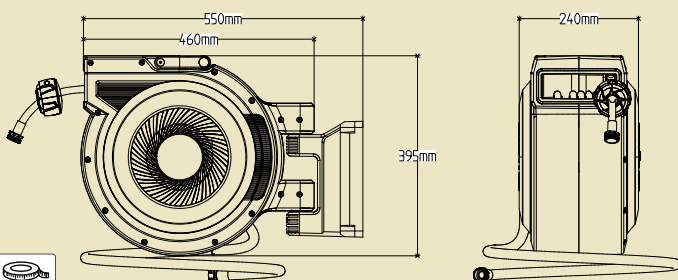

AIR REEL Ø13mm 15m

TN

OP 1119

13 mm



Braided hose

**NEW**

**Specifications:**

- hose: Ø int. 13mm, braided PU hose (polyurethane)
- braked winding
- cable guide with automatic distribution/sweep
- stopping device every 50cm (can be deactivated)
- PP (polypropylene) housing
- 1/4" connection
- 180° swiveling wall bracket
- operating pressure: 10bar

15M **2** WARRANTY





TN

AIR REEL Ø10mm 16m

OP 1017

10 mm



+ ABS Carter

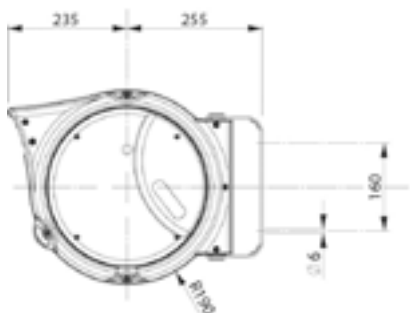

Specifications:

- stop device every 50cm
- hose Øint. 10mm
- connector 3/8"
- adjustable wall support 180°
- max. pressure 15bar
- tension by high
- ABS housing

Option: 4 other colors available



16M



HGV AIR REEL Ø13mm 20m

TN

OP 1628

13 mm

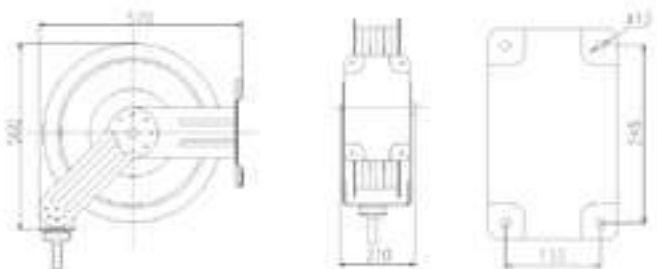

Specifications:

- epoxy powder coated steel brackets
- automatic hose stopping system
- hose Øint. 13mm
- max. pressure: 20bar
- connector 1/2"



20M



HIGH PRESSURE AIR/WATER REEL Ø10mm 20m 280bar

TN

OP 1126

10 mm



Specifications:

- epoxy powder coated steel brackets
- automatic hose stopping system
- reinforced hose SAE 100R1AT
- hose Øint. 10mm
- max pressure 200bar
- hot water max 100°C
- connector 3/8"



20M





# OIL & GREASE REELS

OIL REEL Ø10mm 15m 153bar

HU 1316

TN

10 mm

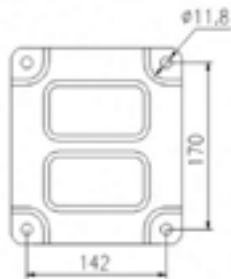
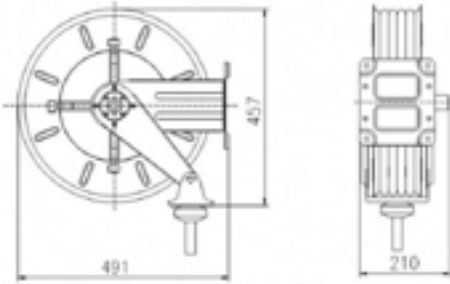

**Specifications:**

- epoxy powder coated steel brackets
- automatic hose stopping system
- reinforced hose SAE 100R2AT
- hose Øint. 10mm
- length 15m, 150°C
- max pressure 153bar
- connector 3/8"



15M



HOSE GREASING REEL Ø8mm 20m 350bar

HU 1818

TN

8 mm

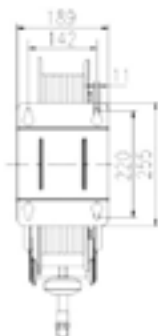
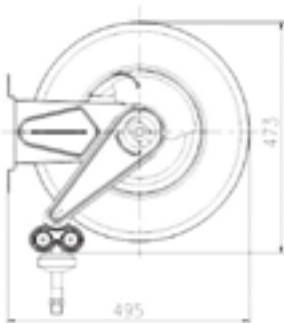

**Specifications:**

- epoxy powder coated steel brackets
- stop device every 50cm
- reinforced hose SAE 100R2AT
- hose Øint. 8mm
- length 20m
- max pressure 350bar
- connector 1/4"



20M





# CABLE REELS

ELECTRICAL WIRE REEL 3x1.5mm<sup>2</sup> 10m

TN

OE 0053BL

**3x1.5**



Automatic cable distribution during winding

**B.LINE**  
BUDGET SOLUTION

**NEW**



**Specifications:**

- cable 3x1.5mm<sup>2</sup> HO7RN-F-20m+1m
- capacity: 1000W-3000W
- cable guide with automatic distribution/ sweep
- automatic 40cm locking (can be deactivated)
- adjustable stop
- 180° adjustable wall bracket
- overtemperature and overvoltage protection
- -5°/+56° operating temperature
- polypropylene housing
- UV protection

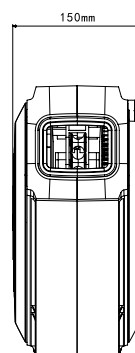
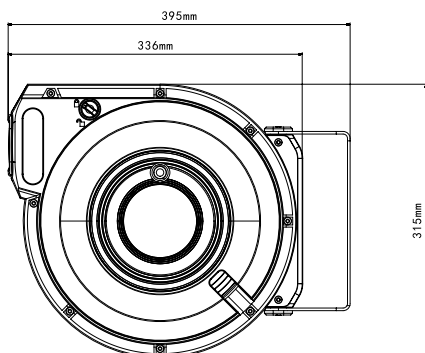

**10M**



WARRANTY



TN

SIGNPOSTING REEL 20m

EG 0017



To signal and define a pit or a dangerous area. Reduces the risk of accidents.

- equipped with a hook to facilitate the delimitation
- anti-UV band
- band width: 40mm
- 180° wall support
- stop device every 50cm



20M



★ TOP PRODUCT

TN

CABLE REELS 3x2,5mm<sup>2</sup> 20m

OE 0428

3x2.5

NEW

+ Automatic cable distribution during winding



Specifications:

- 3x2.5mm<sup>2</sup> HO7RN-F-20m+1m cable
- capacity: 1000W-3000W
- cable guide with automatic distribution/scanning
- free stop at desired length
- adjustable stop
- 180° rotatable wall bracket
- overtemperature and overvoltage protection
- -5°/+56° operating temperature
- polypropylene housing
- UV protection

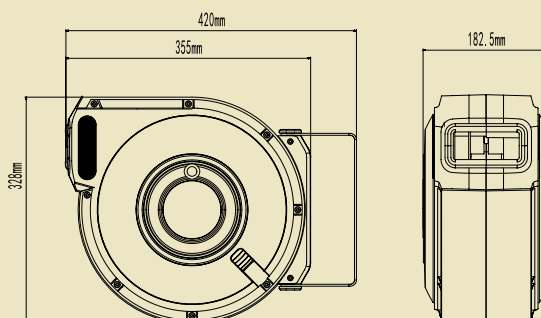

20M





# AIR CONNECTORS

ERP ENDS (x10)  
PASSAGE Ø7.2mm



FAST CONNECTORS EUROPEAN  
PROFILE Ø7.2mm

**NOTE**  
ø7.2mm passage is recommended for painting applications.

	SIZE	MALE THREAD	FEMALE THREAD	REF.	
	1/4"		•	OP 0917	
	3/8"		•	OP 0918	
	1/4"	•		OP 0918	
	3/8"	•		OP 0918	
	Ø8mm			OP 0919	
	Ø10mm			OP 0920	

	SIZE	MALE THREAD	FEMALE THREAD	REF.
	1/4"		•	OP 0717
	3/8"		•	OP 0718
	1/2"		•	OP 0719
	1/4"	•		OP 0720
	3/8"	•		OP 0721
	1/2"	•		OP 0722
	Ø8mm			OP 0723
	Ø10mm			OP 0724

**NOTE**  
ø6mm passage is recommended for LV workshop.

IRP ENDS (x10)  
PASSAGE Ø6mm



FAST CONNECTORS ISO PROFILE Ø6mm

	SIZE	MALE THREAD	FEMALE THREAD	REF.	
	1/4"		•	OP 0901	
	3/8"		•	OP 0902	
	1/4"	•		OP 0903	
	3/8"	•		OP 0904	
	Ø8mm			OP 0906	
	Ø10mm			OP 0907	

	SIZE	MALE THREAD	FEMALE THREAD	REF.
	1/4"		•	OP 0701
	3/8"		•	OP 0702
	1/2"		•	OP 0703
	1/4"	•		OP 0704
	3/8"	•		OP 0705
	1/2"	•		OP 0706
	Ø8mm			OP 0708
	Ø10mm			OP 0709

**NOTE**  
ø8mm passage is recommended for HGV workshop.

IRP ENDS (x10)  
PASSAGE Ø8mm



FAST CONNECTORS ISO PROFILE Ø8mm

	SIZE	MALE THREAD	FEMALE THREAD	REF.	
	1/4"		•	OP 0908	
	3/8"		•	OP 0909	
	1/2"		•	OP 0910	
	1/4"	•		OP 0911	
	3/8"	•		OP 0912	
	1/2"	•		OP 0913	
	Ø8mm			OP 0914	
	Ø10mm			OP 0915	
	Ø13mm			OP 0916	

	SIZE	MALE THREAD	FEMALE THREAD	REF.
	3/8"		•	OP 0710
	1/2"		•	OP 0711
	3/8"	•		OP 0712
	1/2"	•		OP 0713
	Ø8mm			OP 0715
	Ø13mm			OP 0716



# AIR BLOWGUNS

## STRAIGHT BLOWGUN PEN

OP 0099

TN

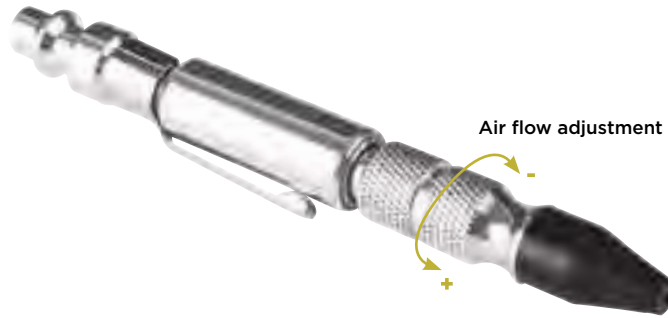

- pocket blowgun
- adjustable flow
- duralumin body
- length 110mm
- opening/closure by rotation



## VARIABLE BLOWGUN BLACK METALLIC NOZZLE

OP 0520

TN



- Specifications:**
- brass insert: 1/4-F
  - progressive blowing
  - nominal pressure: 8bar
  - temperature: -20°C+70°C
  - material: Composite



## SET OF 10 IRP ENDS 6mm PASSAGE MALE 1/4"

OP 0903

TN



## OILER

SA 6206

TN

Spare part of OP 1510/OP 1206/OP 1214/OP 1232/OP 1210/OP 1204/OP 1203/OP 1205/OP 1413/OP 1418/OP 1209/OP 1513/OP 1502/OP 1402/OP 1532/OP 1405/OP 1409/OP 1407/OP 1422/OP 1460/OP 1450/OP 1451/OP 1218/OP 1470/OP 1580/OP 1480/OP 0500/OP 1522BL/OP 1504/OP 1523/OP 1534/OP 1550BL



## 1/4 AIR SPIRAL HOSE L.7.5m

OP 0375

TN



## 1/4" ROTATING UNION

OP 0374

TN





# AIR IMPACT WRENCHES

1/2" D. IMPACT WRENCH 1600Nm DOUBLE HAMMER

TN

OP 1522BL

1/2"

**B.LINE**  
BUDGET SOLUTION



+ One-hand reverser

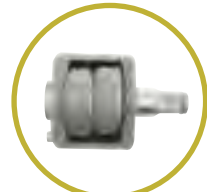

Dual hammer



6-blade rotor



Removable air intake grid for easy cleaning



Steel cage for long service life Less vibration at high torque



Lightweight, high-strength double-injection composite handle



**Specifications:**

- dual hammer technology
- loosening torque: 1600Nm
- tightening torque: 850Nm
- speed: 8,500 rpm
- connection: 1/4"
- recommended hose Ø: 10mm
- supply pressure: 6.2bar
- consumption: 170l/min
- length: 185mm
- net weight: 2.1kg
- supplied with connector



# 1600Nm





TN

1/2" D. IMPACT WRENCH SET 1600Nm FOR WHEELS (19 PCS)

OP 1550BL

1/2"

**B.LINE**  
BUDGET SOLUTION



+ All in one



OP 1522BL



OS 6999



OM 7003BL



OS 3100



SA 6206

**Specifications:**

- double hammer technology
- loosening torque: 1600Nm
- max tightening torque: 850Nm
- speed: 8.500rpm
- connection: 1/4"
- recommended hose Ø: 10mm
- supply pressure: 6.2bar
- consumption: 170l/min
- length: 185mm
- net weight: 2.1kg

**Contents:**

- OP1522BL: 1/2" impact wrench
- 3 special aluminium wheel sockets: 17-19-21mm
- 10 1/2" hexagon sockets: 9-10-11-13-14-17-19-22-24-27mm
- 1/2" extension 125mm
- 4mm hex key
- oil
- oiler
- pneumatic bit

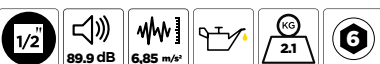

1600Nm



WARRANTY







# 1/2" D. COMPACT IMPACT WRENCH 1200Nm

OP 1523

1/2"



Air circulation around the rotor for cooling



6-blade rotor

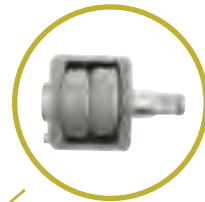

Dual hammer



One-hand reverser



4 positions :  
1 release  
3 tightening

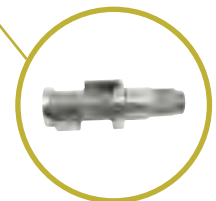

1/2" anvil  
high resistance



Lightweight, high-strength double-injection composite handle



Removable air intake grid for easy cleaning



+ 125mm long  
Only 1.25Kg

**Features :**

- 4-position variator
- exhaust handle
- one-hand reverser

EN ISO 15744:2008  
 EN ISO 4871  
 EN ISO 11148-6:2012

**Specifications:**

- dual hammer technology
- loosening torque: 1200Nm
- tightening torque: 550Nm
- speed: 12,000 rpm
- connection: 1/4"
- recommended hose Ø: 10mm
- supply pressure: 6.2bar
- consumption: 170l/min
- length: 125mm
- net weight: 1.25kg



# 1200Nm





★ TOP PRODUCT

TN

1/2" D. IMPACT WRENCH 2230Nm DOUBLE HAMMER

1/2"

OP 1504

Features:

- 4-position variator
- exhaust handle
- one-hand reverser

EN ISO 15744:2008

EN ISO 4871

EN ISO 11148-6:2012

Specifications:

- double hammer technology
- loosening torque: 2230Nm
- max tightening torque: 1000Nm
- speed: 7.500rpm
- connection: 1/4"
- recommended hose Ø: 10mm
- supply pressure: 6.2bar
- consumption: 170l/min
- length: 185mm
- net weight: 2.2kg



One-hand reverser



+ Powerful One-hand reverser

2230Nm

2 WARRANTY



NOTE

Find the entire range of power tools p.133



3/4" D. IMPACT WRENCH 2298Nm DOUBLE HAMMER

TN

OP 1534

3/4"

Features:

- 4-position variator
- exhaust handle
- one-hand reverser

EN ISO 15744:2008

EN ISO 4871

EN ISO 11148-6:2012

Specifications:

- double hammer technology
- loosening torque: 2298Nm
- max tightening torque: 1068Nm
- speed: 7.500rpm
- connection: 1/4"
- recommended hose Ø: 10mm
- supply pressure: 6.2bar
- consumption: 170l/min
- length: 185mm
- net weight: 2.4kg



One-hand reverser



+ Powerful and compact

2298Nm

2 WARRANTY





TN

### 1" D. IMPACT WRENCH 2441Nm

OP 1407

**+** Ultra-light

1"

- Powerful
- Horizontal work
- Anvil 210mm
- Throttle incorporated into the handle
- 3-position regulator
- Double-hammer technology
- Lateral exhaust



Two-handed grip



Reverser close to the second hand

**Specifications:**

- max. torque: 2441Nm
- release torque: 2033Nm
- speed: 6,000rpm
- length: 467mm
- connection: 1/2"
- supply pressure: 6.2bar
- consumption: 282l/min
- net weight: 7.5kg

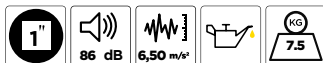

# 2441Nm



### 1" D. HGV IMPACT WRENCH 3390Nm

OP 1422

1"

- Powerful
- Horizontal work
- Anvil 210mm
- Throttle incorporated into the handle
- 3-position regulator
- Double-hammer technology
- Lateral exhaust



**Specifications:**

- max. torque: 3390Nm
- speed: 5,000rpm
- length: 565mm
- connection: 1/2"
- supply pressure: 6.2bar
- consumption: 282l/min
- net weight: 11kg

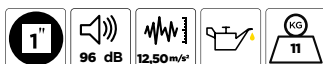

# 3390Nm





# AIR RATCHET WRENCHES

## 3/8" D. RATCHET WRENCH

TN

OP 1413

- Quiet
- Integrated speed regulator
- Needle bearing
- Reinforced head
- Ergonomic handle
- Reversible
- Swiveling connector
- Rear exhaust

**Specifications:**

- max. torque: 68Nm
- working torque: 14 to 68Nm
- speed: 150rpm
- length: 256mm
- connection: 1/4"
- supply pressure: 6.2bar
- consumption: 113l/min



3/8"

Connector supplied



## 1/2" D. RATCHET WRENCH

TN

OP 1209

- quiet
- light
- integrated speed regulator
- needle bearing
- reinforced head
- ergonomic handle
- reversible
- swiveling connector
- rear exhaust

**Specifications:**

- max. torque: 68Nm
- working torque: 14 to 68Nm
- speed: 150rpm
- length: 256mm
- connection: 1/4"
- supply pressure: 6.2bar
- consumption: 113l/min



1/2"

Connector supplied



## 1/4"-3/8" D. MINI RATCHET WRENCH KIT

TN

OP 1510

**Specifications:**

- speed: 850rpm
- max torque: 40.7Nm
- consumption: 113l/min
- length: 155mm
- 3 positions: forward/reverse/fixed

**Contents:**

- connector
- SA1510: square reversible adapter 1/4"-3/8"
- bit holder adapter



1/4" - 3/8"

Connector supplied





# AIR DRILLS

## Ø13mm REVERSIBLE DRILL

OP 1451

- Two-speed trigger
- Automatic chuck
- Silent
- Composite housing
- Ergonomic handle + additional handle
- Swivelling connector
- Bottom exhaust with silencer
- Reversing bar on both sides
- Inversion of the rotation direction with one hand accessible from both sides

### Specifications:

- motor: 0.5cv
- speed: 800rpm
- length: 218mm
- connector: 1/4"
- supply pressure: 6.2bar
- consumption: 113l/min

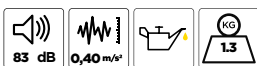

Connector supplied



TN

### NOTE

Discover the complete range of portable power tools p.133

## DRILL SET HSS4241 (170 PCS)

EG 0671BL



TN



## DRILL SET HSS COBALT 5% (170 PCS)

EG 0681

HSS drills with 5% cobalt have an increased life and can drill hard metals such as stainless steel.



TN

## DRILL SET HSS4241 (25 PCS)

EG 0670BL



TN

## DRILL SET HSS COBALT 5% (25PCS)

EG 0680



TN



TN

## AIR RIVETER KIT

OP 1475



**+** 900Kg pulling force

Connector supplied

**Specifications:**

- rivet capacity up to 4.8mm depending on the bit
- traction power: 900kg
- stroke length: 14mm
- bits: 2.4-3,2-4-4.8mm
- air inlet: 1/4"
- air pressure: 6.2bar
- consumption: 1.4 to 1.8l/min



SA 1475 5 PCS NOZZLES+RIVETER JAWS SET

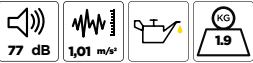

## SPOT DRILL

OP 1460

- quiet
- low speed/high torque
- locking swivel clamp
- ergonomic handle
- rotating intake connection
- bottom exhaust
- carbide burr not included



**+** High torque

Connector supplied

**Specifications:**

- speed: 800tr/min
- for reamer: Ø6.3/8.3/10.3x47mm
- length: 349mm
- connection: 1/4"
- supply pressure: 6.2bar
- consumption: 113l/min



SA 1460 CARBIDE REAMER 8.3x47mm

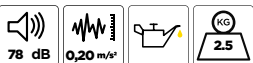



# AIR CUTTING TOOLS

## CHISEL HAMMER SET

TN

OP 1580

Chisel set for easier removal of corroded, seized or crimped parts.



**Specifications:**

- capacity: 3200bpm
- operating pressure: 6.5bar
- connector 1/4"
- consumption: 180l/min

**Contents:**

- SA1586: vibro chisel
- SA1580: spring
- SA1581: flat chisel 20mm
- SA1582: curved chisel (welding spots+rivets)
- SA1583: punch
- SA1584: cutting chisel
- SA1585: splitter chisel
- accessories: Ø10mm
- length of accessories plug: 43mm



## PNEUMATIC CHISEL TOOLS

TN

OP 1480

Chisel set for an easier removal of corroded, seized or crimped parts.



**Specifications:**

- capacity: 2200bpm
- operating pressure: 5 to 8bar
- consumption: 114l/min
- noise level 100dB

**Contents:**

- SA1480: chipping/chisel hammer
- SA1481: adapter for 1/2" D. impact sockets
- SA1482: adapter for Ø38-63-74mm blocks
- SA1483: circular shaped block Ø38mm
- SA1484: rounded hollow block Ø63mm
- SA1485: circular shaped block Ø74mm
- SA1486: circular shaped block Ø25mm
- SA1487: rounded hollow block Ø25mm
- SA1488: 10pcs O-rings





TN

## 10mm AIR BODY SAW

OP 1470

- light
- composite body
- low vibration
- swiveling connector
- safety trigger
- ergonomic handle with protection

**+** Supplied with 2 blades and swivel



**Specifications:**

- strokes/min: 9500
- stroke length: 10mm
- length: 300mm
- connector: 1/4"
- supply pressure: 6.2bar
- consumption: 90l/min

**Options:**

SA1472: set of 5 blades with 24 teeth + 5 blades with 32 teeth

- Supplied with:
- connector
  - SA1470: 24-tooth blade 74mm
  - SA1471: 32-tooth blade 74mm



SA 1470 24-TOOTH BLADE

SA 1471 32-TOOTH BLADE

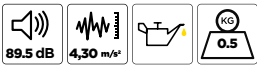

## REVERSIBLE DISK-SANDER

OP 1214

- powerful
- composite housing
- reversing bar on both sides
- rear exhaust with silencer

**Specifications:**

- speed: 16,000rpm
- plates: 75/100/125mm
- motor: 0.60cv
- length: 142mm
- connector: 3/8"
- supply pressure: 6.2bar
- consumption: 113l/min



Connector supplied

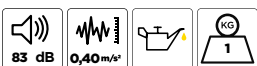





# AIR GRINDERS

## MINI DIE GRINDER Ø6mm 25,000rpm

TN

OP 1203



- lightweight
- grip handle
- safety trigger
- rear exhaust with silencer
- variable speed drive
- rotating intake connection

Connector supplied

**Specifications:**

- speed: 25,000rpm
- length: 159mm
- connection: 1/4"
- supply pressure: 6.2bar
- consumption: 113l/min

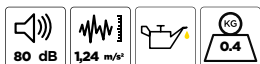

# 25000trs/min



CO 1201	ABRASIVE HOLDER DISC TRAY SUPPORT AXLE Ø50mm	Accessory of OP 1421/OP 1203/OP 1204/OP 1205/CO 1202
CO 1202	ABRASIVE DISC HOLDER TRAY Ø50mm	Accessory of OP 1203/OP 1204/OP 1205/CO 1201/CO 1203/CO 1204/CO 1205
CO 1203	50 ABRASIVE DISCS P40 Ø50mm	Accessory of OP 1203/OP 1204/OP 1205/CO 1202
CO 1204	50 ABRASIVE DISCS P60 Ø50mm	Accessory of OP 1203/OP 1204/OP 1205/CO 1202
CO 1205	50 ABRASIVE DISCS P80 Ø50mm	Accessory of OP 1203/OP 1204/OP 1205/CO 1202
SA 1203	DRILLED SHAFT SUPPORT DISKS	Accessory of OP 1203/OP 1204/OP 1205



## MINI DIE GRINDER Ø6mm 20,000rpm

TN

OP 1204



- Light
- Grip handle
- Safety throttle
- Rear exhaust with silencer
- Speed regulator
- Swiveling connector

Connector supplied

**Specifications:**

- speed: 20,000rpm
- length: 188mm
- connection: 1/4"
- supply pressure: 6.2bar
- consumption: 113l/min

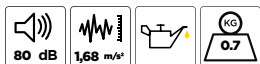

# 20000trs/min



## MINI ANGLE DIE GRINDER Ø6mm

TN

OP 1205



- Light
- Grip handle
- Safety throttle
- Rear exhaust with silencer
- Speed regulator
- Swiveling connector

Connector supplied

**Specifications:**

- speed: 20,000rpm
- angle: 115°
- vibration: 1.24m/s²
- connection: 1/4"
- supply pressure: 6.2bar
- consumption: 113l/min

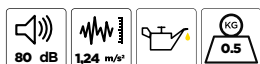



TN

## RUBBER GRINDER

OP 1222

Ideal for damage-free removal of any stickers or traces of glue.

**Specifications:**

- speed: 25,000 rpm
- length: 159mm
- connection: 1/4"
- supply pressure: 6.2bar
- consumption: 113l/min
- supplied with fitting

OP1203 : 1 x mini meuleuse droite ø6mm 25000trs/min  
 SA1421 : 1 x gomme ø86mm  
 SA1422 : 1 x adaptateur

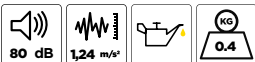

## MULTI-SERVICE BRUSH

OP 1210

- light
- safety guard
- grip handle + auxiliary handle
- use with gum or brush
- safety throttle
- rear exhaust



SA 1209	WIRE BRUSH (FINE) L.23mm
SA 1210	METAL BRUSH L.23mm
SA 1211	HARD GUM Ø105mm
SA 1212	SOFT GUM Ø105mm
SA 1213	ADAPTER FOR GUM AND BRUSH

**Specifications:**

- speed: 3,500rpm
- length: 280mm
- connection: 1/4"
- supply pressure: 6.2bar
- consumption: 110l/min

Supplied with:

- connectors
- SA1210: metal brush L.23mm
- SA1213: adapter for gum and brush Ø23mm

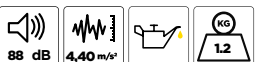

## MICROGRAIN PNEUMATIC SANDBLASTING BOOTH

OP 0618

This sandblasting booth is ideal for microblasting average sized parts. Hooked up to the workshop's air system, it allows you to blast abrasives for cleaning and restoring, making parts look like new.

**Specifications:**

- glazed access hatch
- hatch protective film
- neon interior light
- reinforced rubber handing gloves
- compatible with abrasives: microbead glass, corindon, shot, plastic media
- gun supplied with 4 ceramic nozzles (Ø 4, 5, 6 et 7mm)
- external dimensions: L.625xH.490xD.490mm
- internal dimensions: L.490xH.395xD.290mm
- air flow: 1.5m³ at 80psi.

Spare parts:

- SA6614: drum of synthetic sand 25kg (not included)
- SA0640: gun
- SA0641: ceramic nozzle
- SA0642: glove clamp
- SA0643: gloves
- SA0644: plexiglass for trapdoor
- SA0645: air filter



SA 6614	SYNTHETIC SAND CARDBOARD 25kg
---------	-------------------------------





# GUN

## AIR CAULKING GUN

OP 5061

For the application of silicones, glues and putties with 310ml cartridges.

**Specifications:**

- aluminum body
- total length: 325mm
- 1/4" connection
- supply pressure: 5bar
- progressive trigger to enable speed control



Connector supplied



TN

## PNEUMATIC GUN FOR 370mm CARTRIDGES AND BAGS

OP 5060

For silicones, glues, putties application with 310ml cartridges and 300,400 and 600ml bags.

**Specifications:**

- aluminum body and ring
- total length: 470mm
- length: 370mm
- height: 270mm
- sound level: 80dB
- air pressure inlet regulator from 4 to 8bar (10bar maximum) with 1/4" connection
- valve strength: 160kgf to 8bar
- progressive trigger to enable speed control



Connector and plastic spout supplied



TN

## CARTRIDGE SPRAY GUN (POLYMER MS)

OP 1338

Allows the application of sealants, seals and waterproofing adhesives sprayable with 310ml cartridges. Spray or extrusion application.



**Specifications:**

- adjustable pressure and flow rate
- operating pressure: 3-5bar

Supplied with spray and extrusion nozzle



TN

## PNEUMATIC GREASING GUN 450ml

OP 0521

### NOTE

Grease gun p. 104



**Specifications:**

- nozzle length: 170mm
- capacity: 450ml
- operating pressure: 6.2bar
- weight: 1.8kg



TN



SCREEN ADHESIVE CARTRIDGE 290ml

TN

CO 1041

Specifications:

- MS polymer
- integrated primer
- application width 10 to 14mm
- drying: 2 hours at heart (at 20°C)
- hardness: SHORE 60



WHITE GLUE AND MASTIC CARTRIDGE 310ml

TN

CO 1022



GREY GLUE AND MASTIC CARTRIDGE 310ml

CO 1047



BLACK GLUE AND MASTIC CARTRIDGE 310ml

CO 1048



Adhesion without primer on metallic surfaces

Specifications:

- elastomer: 300% elasticity
- touch dry: 5-10min
- without solvent

Also available in box of 12



ANTI GRAVEL MS POLYMER BLACK CARTRIDGE 310ml

TN

CO 1034



ANTI GRAVEL MS POLYMER BEIGE CARTRIDGE 310ml

CO 1057



ANTI GRAVEL MS POLYMER GREY CARTRIDGE 310ml

CO 1058



Ideal for sprayed seals



Easy to install, giving an optimal result. Ideal for application on bare metal.

This cutting-edge product can be applied wet-on-wet to obtain an optimal anti stone-chip effect in record time.

Adheres to all surfaces

Anti-corrosive, may even be applied to bare metal

High density: load up to 5mm in a single movement

Also permits the reproduction of seals which were originally sprayed and crimped seals





# AIR SANDERS

TN

## 5mm

5mm RANDOM ORBITAL PALM SANDER

Ø150mm

OP 1311

## 2.5mm

2.5mm RANDOM ORBITAL PALM SANDER

Ø150mm

OP 1312

**Specifications:**

- speed: 12,000rpm
- orbit: 5mm
- pad: Ø150mm
- length: 196mm
- connector: 1/4"
- supply pressure: 6.2bar
- consumption: 57l/min
- net weight: 0.7kg
- ultra-light composite body with anti-vibration belt
- speed regulator
- rear exhaust
- Ø32mm connection for cuff
- one-handed use



Connector supplied



CO 1311 MEDIUM MULTI-HOLE VELCRO® TRAY Ø150mm/8mm

CO 1312 3 FLEXIBLE INTERFACES Ø150/5mm

CO 1313 3 FLEXIBLE INTERFACES Ø150/10mm

## 10mm BELT SANDER

OP 1445



- SA 1447 5 SANDING STRIP 80+5 SANDING STRIP 120 SET
- SA 1446 SANDING STRIP 120
- SA 1445 SANDING STRIP 80

**Specifications:**

- speed: 18,000rpm
- belt: 10mmx330mm
- max. length: 330mm
- length folded: 207mm
- connection: 1/4"
- supply pressure: 6.2bar
- consumption: 116l/min

- Safety throttle
- Covered grip
- Handle exhaust + silencer
- Swiveling connector
- Safety lever

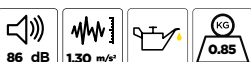

Connector supplied





# PORTABLE POWER TOOLS

## THE MUST AT YOUR FINGERTIPS



POWERFUL ■ ERGONOMIC ■ PERFORMANCE ■ RELIABLE

A **compact, high performance, premium-quality** range with a very affordable budget. Featuring the latest technologies, our products will bring you confidence in your day-to-day operations.

Our products are guaranteed for **3 years**.



**BRUSHLESS** engine:

- no maintenance required
- reduced consumption
- more efficient
- longer life.



### ELECTRONIC MANAGEMENT FOR GREATER SAFETY:

- Controlled release
- Safety clutch
- Progressive release trigger

**BRUSH  
LESS  
MOTOR**



**KICKBACK  
CONTROL**

Anti-bounce protection (depending on model)

**STEEL  
STRUCTURE**



Overload protection



Overheating protection



**LED**



### BATTERY:

- 1.4Ah/20V battery compatible with our entire range
- High capacity
- Intelligent electronic management for longer service life
- Integrated load indicator
- Charge and discharge control





TN

# 1/2" IMPACT WRENCH 620Nm 20V BRUSHLESS + 2 BATTERIES 4Ah + CHARGER

PW 0620

**+** Compact and lightweight

**1/2"**

**MAX**



**AUTO STOP MODE**

**1**



**2**



### Specifications:

- max. breakaway torque 620Nm
- max. tightening torque 450/290Nm
- max. power output (MWO): 500W
- 2 speeds
- stroke rate: 3600/2500 (imp/min)
- idle speed: 2700/1700 (rpm)
- drive: 1/2" diameter
- max. bolt Ø: M20
- voltage: 20V
- Led lighting
- vibration: ah=2.5m/s<sup>2</sup>, K=1,5m/s<sup>2</sup>.
- sound power level: Lw=107dB(A), K=3dB(A)
- sound pressure: Lp=99dB(A), K=3dB(A)
- weight: 1.10Kg (without battery) / 1.75Kg (with battery)
- dimensions LxWxH: 130x80x260mm

### ADVANTAGE

Compatible with Makita batteries  
 Auto stop" mode on loosening: when the bolt is sufficiently loosened, the tool automatically stops in less than a second.

Supplied in transportable case with 2 batteries 4.0Ah and charger 2.3A

340 Autonomy bolts (M19)\*  
 \*[indicative value]



# 620Nm



# 1/2" IMPACT WRENCH 620Nm 20V BRUSHLESS WITHOUT BATTERY

TN

PW 0621



REF	DESIGNATION
PW 9004	20V 4Ah LI-ION BATTERY
PW 9102	PORTABLE BATTERY CHARGER 2.3A
PW 9104	ELECTROPORATIVE BATTERY QUICK CHARGER 4Ah

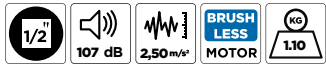



TN

1/2" IMPACT WRENCH 1080Nm 20V  
BRUSHLESS + 2 BATTERIES 4Ah + CHARGER

PW 1080

**+** Strong torque

1/2"

**MAX**



**AUTO STOP MODE**

**1**



**2**



**3**



Aluminum body

3 speeds



LED lighting



Moteur BRUSHLESS



1-hand inverter



Battery level indicator

Lithium-ion battery high-performance 4Ah

**Specifications:**

- max. breakaway torque : 1080Nm
- max. tightening torque 860/500/300Nm
- max. power output (MWO): 800W
- 3 speeds
- stroke rate: 2200/1900/1500 (imp/min)
- idle speed: 2400/1900/1500 (rpm)
- drive: 1/2"
- max. bolt Ø: M24
- voltage: 20V
- Led lighting
- vibration: ah=9.3m/s<sup>2</sup>, K=1.5m/s<sup>2</sup>.
- sound power: Lw=109dB(A), K=3dB(A)
- sound pressure: Lp=98dB(A), K=3dB(A)
- weight: 1.90Kg (without battery) / 2.55Kg (with battery)
- dimensions (LxWxH): 170x85x280mm

**ADVANTAGE**

Compatible with Makita battery  
"Auto stop" mode on loosening: trigger fully depressed, when the bolt is sufficiently loosened the tool automatically stops in less than a second.

Supplied in transportable case with 2 batteries 4.0Ah and charger 2.3A

300 Autonomy bolts (M19)\* \*[indicative value]



1080Nm

**3** WARRANTY



1/2" IMPACT WRENCH  
1080Nm 20V BRUSHLESS  
WITHOUT BATTERY

PW 1081



TN



REF	DESIGNATION
PW 9004	20V 4Ah LI-ION BATTERY
PW 9102	PORTABLE BATTERY CHARGER 2.3A
PW 9104	ELECTROPORTATIVE BATTERY QUICK CHARGER 4Ah

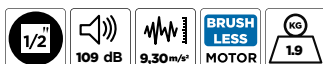

**3** WARRANTY





TN

20V BRUSHLESS HAMMER DRILL + 2  
BAT 4Ah + CHARGER

PW 2013

+ Ø13mm self-clamping steel chuck

13mm

3 MODES



40 mm



13 mm



13 mm

MAX

1

2

160 Nm

0-600 rpm

0-2250 rpm



BRUSHLESS motor



1-hand inverter



LED lighting



Battery level indicator



Lithium-ion battery high-performance 4Ah

Specifications:

- 2 speeds
- torque: 160Nm
- max. power output (MWO): 900W
- stroke rate: 0/36000 (imp/min)
- idle speed: 0-600/0-2250 (rpm)
- self-tightening chuck: 13mm
- chuck capacity: 1.5 / 13mm drill bit
- torque settings: 20 + 3
- steel drilling capacity: 13mm
- wood drilling capacity: 40mm
- masonry drilling capacity: 13mm
- voltage: 20V
- weight: 2.0Kg (without battery) / 2.65Kg (with battery)
- Led lighting
- vibration: ah=1.4m/s<sup>2</sup>, K=1.5m/s<sup>2</sup>
- sound power level: Lw=91.8dB(A), K=3dB(A)
- sound pressure: Lp=80.8dB(A), K=3dB(A)
- dimensions (LxWxH): 205x65x260mm

ADVANTAGE

Compatible with Makita batteries

Supplied in transportable case with 2 batteries 4.0Ah and charger 2.3A

50-hole autonomy (Ø10mm / 3mm sheet metal)\*  
\*[indicative value]



20V 4Ah 91.8 dB 1,40 m/s<sup>2</sup> BRUSH LESS MOTOR 2.65

160Nm

3 WARRANTY

20V BRUSHLESS HAMMER DRILL WITHOUT BATTERY

TN

PW 2014



REF	DESIGNATION
PW 9004	20V 4Ah LI-ION BATTERY
PW 9102	PORTABLE BATTERY CHARGER 2.3A
PW 9104	ELECTROPORTATIVE BATTERY QUICK CHARGER 4Ah

91.8 dB 1,40 m/s<sup>2</sup> BRUSH LESS MOTOR 2.00

3 WARRANTY



TN

ANGLE GRINDER 125mm 20V BRUSHLESS + 2 BATTERIES 4Ah + CHARGER

PW 3125

125mm

+ Stop in 3 seconds



M14



35mm



8500 tr/min

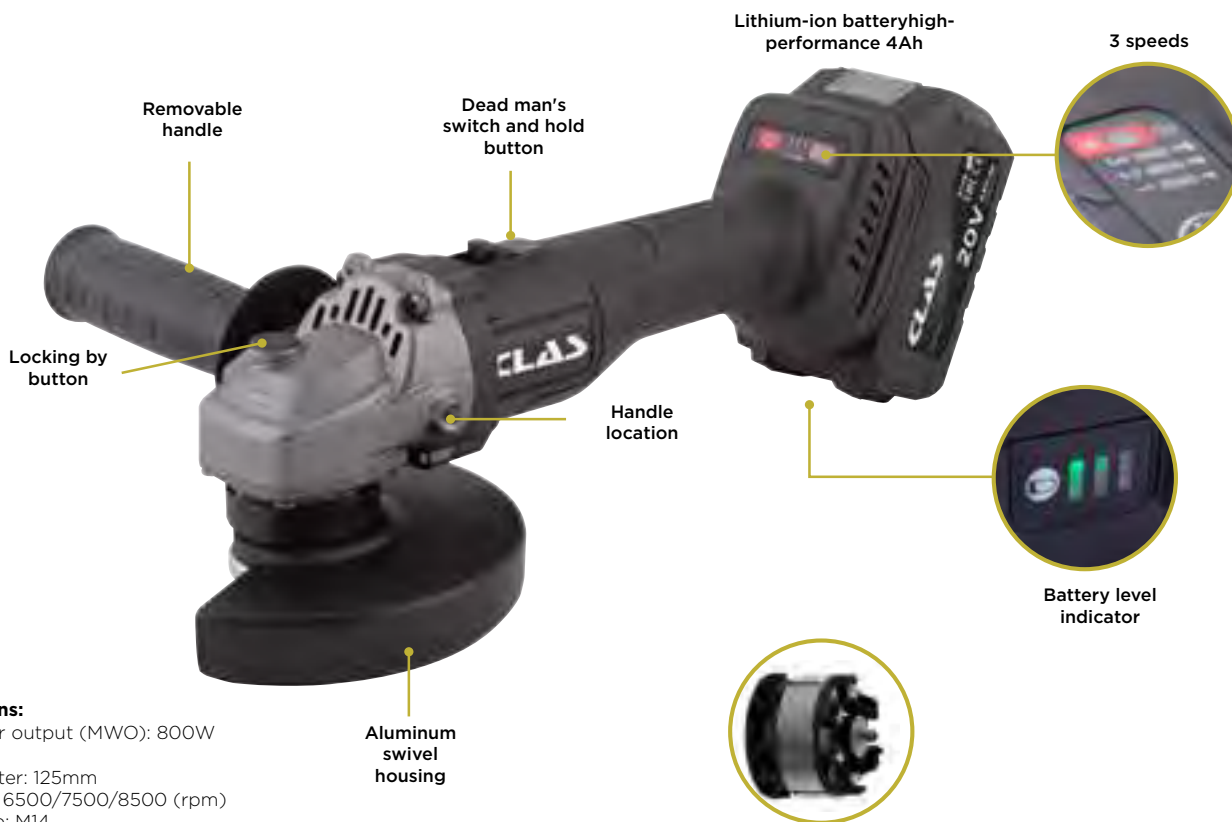

**Specifications:**

- max. power output (MWO): 800W
- 3 speeds
- disc diameter: 125mm
- idle speed: 6500/7500/8500 (rpm)
- spindle size: M14
- soft start
- blade stop: 3s
- cutting depth: 35mm
- voltage: 20V
- Led lighting
- grinding vibration: ah=5.5m/s<sup>2</sup>, K=1.5m/s<sup>2</sup>.
- sanding vibration: ah=1.9m/s<sup>2</sup>, K=1.5m/s<sup>2</sup>.
- sound power: Lw=93.4dB(A), K=3dB(A)
- sound pressure: Lp=82.4dB(A), K=3dB(A)
- weight: 1.20Kg (without battery) / 1.85Kg (with battery)
- dimensions (LxWxH): 300x105x80mm

**ADVANTAGE**

Compatible with Makita batteries

Supplied in transportable case with 2 x 4.0Ah batteries and 2.3A charger

50 cuts autonomy (Ø10mm steel bar)\*  
\*[indicative value].

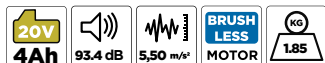

ANGLE GRINDER 125mm 20V BRUSHLESS WITHOUT BATTERY

TN

PW 3126



REF	DESIGNATION
PW 9004	20V 4Ah LI-ION BATTERY
PW 9102	PORTABLE BATTERY CHARGER 2.3A
PW 9104	ELECTROPORTATIVE BATTERY QUICK CHARGER 4Ah





# PORTABLE POWER TOOLS

← FIND THE ALL PORTABLE POWER TOOLS RANGE HERE

## PACK BAG + 2 POWER TOOLS

TN

PW 8030

PW 9004

x2

PW 0621

PW 2014

EG 3110

PW 9104

NEW

EG3110 : 1 x shoulder tool bag  
 PW0621 : 1 x 1/2" impact wrench 620nm 20v brushless without battery  
 PW2014 : 1 x 20v brushless hammer drill without battery  
 PW9104 : 1 x electroportative battery quick charger 4h  
 PW9004 : 2 x 20v 4ah li-ion battery

## PACK BAG + 3 POWER TOOLS

TN

PW 8020

NEW

PW 2014

PW 3126

x2

PW 9004

PW 1081

PW 9104

EG 3110

EG3110 : 1 x shoulder tool bag  
 PW1081 : 1 x 1/2" impact wrench 1080nm 20v brushless without battery  
 PW2014 : 1 x 20v brushless hammer drill without battery  
 PW3126 : 1 x angle grinder 125mm 20v brushless without battery  
 PW9104 : 1 x electroportative battery quick charger 4h  
 PW9004 : 2 x 20v 4ah li-ion battery

## PACK BAG + 4 POWER TOOLS

TN

PW 8010

PW 9004

x3

PW 3126

PW 1081

PW 2014

EG 3110

NEW

x2

PW 9104

PW 0621

EG3110 : 1 x shoulder tool bag  
 PW0621 : 1 x 1/2" impact wrench 620nm 20v brushless without battery  
 PW1081 : 1 x 1/2" impact wrench 1080nm 20v brushless without battery  
 PW2014 : 1 x 20v brushless hammer drill without battery  
 PW3126 : 1 x angle grinder 125mm 20v brushless without battery  
 PW9104 : 2 x electroportative battery quick charger 4h  
 PW9004 : 3 x 20v 4ah li-ion battery



DRILL + BITS PACK

TN

PW 8050



NEW



Supplied in transportable case with 2 batteries 4.0Ah and charger 2.3A

PW2013 : 1 x 20v brushless hammer drill + 2 bat 4ah + charger  
EG0680 : 1 x drill set hss cobalt 5% (25pcs)

50-hole autonomy (Ø10mm / 3mm sheet metal)\* \* [indicative value]

BOLT GUN + WHEEL SOCKET PACK

TN

PW 8040



NEW



Supplied in transportable case with 2 batteries 4.0Ah and charger 2.3A

PW1080 : 1 x 1/2" impact wrench 1080nm 20v brushless + 2 batteries 4ah + charger  
OM7025 : 1 x 1/2" sheathed alu wheel rim socket set (5 pcs)  
OM0792 : 1 x torque wrench 1/2" 40-220nm

300 Autonomy bolts (M19)\* \* [indicative value]

ELECTROPORABLE TOOL HOLDER & ACCESSORIES

TN

PW 9150

Accessory of PW 0620/PW 0621/PW 1080/PW 1081/PW 2013/PW 2014/PW 3125/PW 3126/PW 9104/PW 9102/PW 9004

Ideal for storing your tools and keeping them close at hand!

Holds 4 tools, plus charger and batteries on the shelf.  
Supplied with fixing kit.

NEW



2 WARRANTY



# WORKBENCHES

TN

## 1.5m WORKBENCH SET

EG 0311

**+** Hight weight capacity 700kg

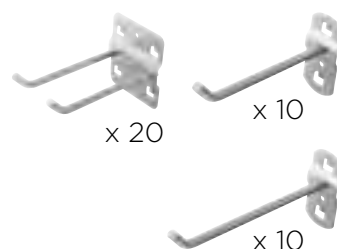
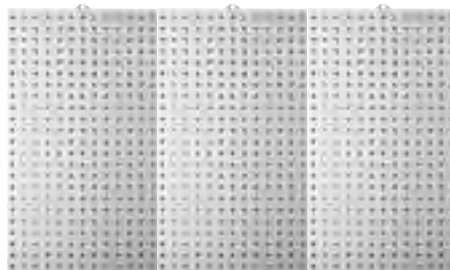

Dimensions:

- wooden trays: L.1500xI.750xH.30mm
- framework: L.1410xI.692xH.855mm
- storage (metal plate): L.1410xI.610mm
- weight: 95kg

EG0335 : 1 x metal workbench wooden tray 1.5m  
 EG0337 : 1 x drawer  
 EG0344 : 2 x bag of 10 double hooks ø6mm I.50mm  
 EG0346 : 1 x bag of 10 simple hooks ø6mm I.50mm  
 EG0347 : 1 x bag of 10 double hooks ø6mm I.100mm  
 EG0357 : 3 x perforated panel tool rack 500x900x30mm

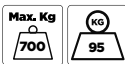

## 2m WORKBENCH SET

EG 0312

**+** Hight weight capacity 700kg

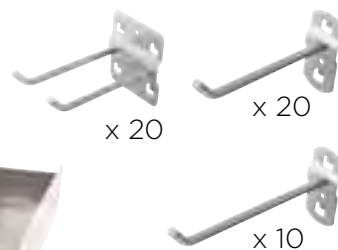
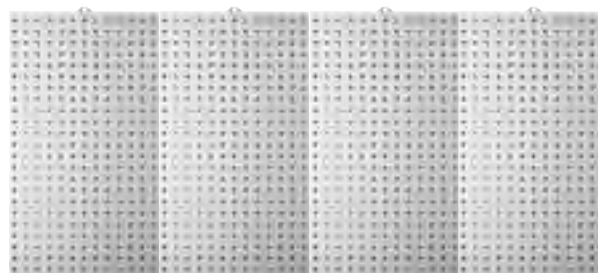

Dimensions:

- wooden trays: L.2000xI.740xH.30mm
- framework: L.1900xI.692xH.855mm
- storage (metal plate): L.1900xI.610mm
- weight: 120kg

EG0336 : 1 x metal workbench wooden tray 2m  
 EG0357 : 4 x perforated panel tool rack 500x900x30mm  
 EG0344 : 2 x bag of 10 double hooks ø6mm I.50mm  
 EG0346 : 2 x bag of 10 simple hooks ø6mm I.50mm  
 EG0347 : 1 x bag of 10 double hooks ø6mm I.100mm  
 EG0337 : 2 x drawer

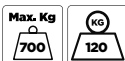



TN



METAL WORKBENCH WOODEN TRAY 1.5m

EG 0335

Dimensions:

- wooden trays: L.1500xI.750xH.30mm
- framework: L.1410xI.692xH.855mm
- storage (metal plate): L.1410xI.610mm
- weight: 95kg
- possibility to fit 1 drawer only EG0337 (not included)



High weight capacity 700kg



METAL WORKBENCH WOODEN TRAY 2m

EG 0336

Dimensions:

- wooden trays: L.2000xI.740xH.30mm
- framework: L.1900xI.692xH.855mm
- storage (metal plate): L.1900xI.610mm
- weight: 120kg
- possibility to fit 1 drawer only EG0337 (not included)

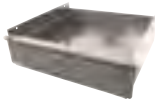

EG 0337 DRAWER

Accessory of EG 0335/EG 0336/EG 0311/EG 0312



PERFORATED PANEL TOOL RACK 500x900x30mm

EG 0357

Accessory of EG 0335/EG 0336/EG 0311/EG 0312

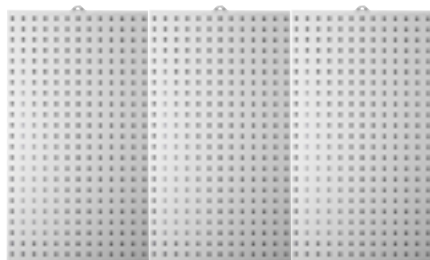

Modular to meet your needs, EG0357 panels have been designed to be assembled together.



Perforation, square 10x10, clearance 38mm



BAG OF 10 DOUBLE HOOKS Ø6mm L.50mm

EG 0344

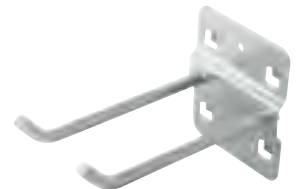

BAG OF 10 SIMPLE HOOKS Ø6mm L.50mm

EG 0346

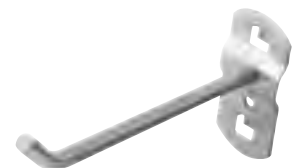

BAG OF 10 DOUBLE HOOKS Ø6mm L.100mm

EG 0347



Ø hook: 6mm  
Hook length: 50mm  
Tip 45°  
Squared perforated panel fixing 10x10mm (38mm gap)





### BODYWORK 3 TRAY STORAGE TROLLEY

TN

OC 0711

Allows parts which have been uninstalled to be put away and stored such as headlights, headrests, instrument panels, bumpers...

**Specifications:**

- 3 trays (2 wooden and 1 mesh)
- platform height: 260-810-1390mm
- mesh base
- 4 swiveling wheels, 2 of which have brakes
- dimensions: L.630xW.1110xH.1625mm



### 3 TRAY ROLLER CABINET

TN

EG 0083

**Specifications:**

- overall dimensions: 766x415x840mm
- tray dimensions: 760x410x60mm
- 2 fixed casters Ø100mm
- 2 swiveling casters Ø100mm with brakes
- 2.5mm thick EVA foam tray protection
- admissible load per shelf: 30kg
- total admissible load: 90kg



### 900W INDUSTRIAL BENCH GRINDER Ø200x32x32mm WHEEL+BRUSH

EG 0225

**Specifications:**

- adjustable protective screen with magnifying lens
  - dual extractor vent
  - speed: 2950 rpm
- Fixing:
- 250mm wide centre distance
  - 155mm deep centre distance

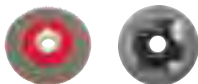

EG 0221 BENCH GRINDER BRUSH

EG 0273 VITRIFIED GRINDING WHEEL GREY CORUNDUM 200x32x32mm GRIT 60



Supplied with:

- brush Ø200mm
- grinding wheel grit 60



### PARALLEL JAW CLAMPS 150mm QUICK TUBE HOSE APPROACH

OM 4066

**Specifications:**

- jaw width: 150mm
- jaw height: 20mm
- opening: 180mm
- interchangeable steel jaws
- supplied with revolving base with 3 anchoring points
- weight: 24kg



Quick approach

Releasable jaw system allowing you to make adjustments to the jaw immediately.

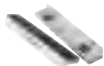

EG 7053 150mm 2 RUBBER COATING MAGNETIC JAW SET

EG 7054 200mm 2 RUBBER COATING MAGNETIC JAW SET

EG 7050 2 JAW 150mm SET

EG 7051 2 JAW 200mm SET

TN





# SMALL WORKSHOP EQUIPMENT

## FOLDABLE INSPECTION CREEPER

EG 0113BL

Workshop creeper

Can be dismantled into 2 parts, with 4 swivel castors, easy to transport in a trunk.  
Comfortable, padded cushion and headrest.



**Specifications:**

- dimensions: 92x38x9.5cm

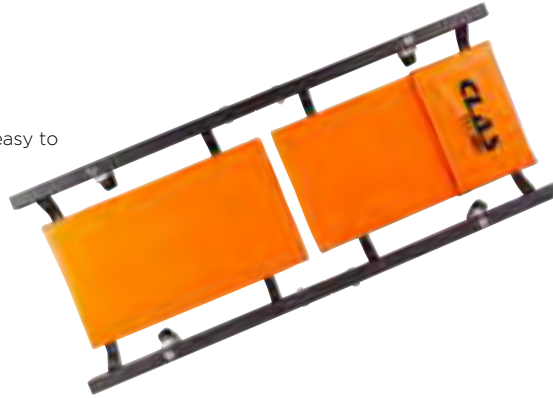

TN



## ★ TOP PRODUCT

## 6-WHEEL BUCKET-SEAT INSPECTION CREEPER

EG 0106

**Specifications:**

- supplied with 2 tool racks
- carrying handle
- hydrocarbon-proof material
- dimensions: 100x48x11cm
- wheel Ø: 60mm
- high-pressure washable



TN



## INSPECTION CREEPER 150kg

EG 0109

**Specifications:**

- equipped with 2 tool holders
- carrying handle
- hydrocarbon-resistant material
- dimensions: 100x47x13cm
- Wheel Ø: 75mm
- high pressure washable
- reinforced wheel support



TN



## TOOL-STORAGE STOOL

OM 0099

**Specifications:**

- height-adjustable
- 2 levels of tool storage
- allows you to work on all low parts
- h. min.: 440mm
- h. max.: 560mm
- weight capacity: 113kg



TN







### HOT AIR GUN 50-650°C

OE 6047

TN



**Specifications:**

- LCD display
- last temperature memorized
- 5 options for airflow from 250 to 500l/min
- heat constant control (protects against overheating and ensures a continuous job)
- handle for a comfortable job
- operating temperature range: 50-650°C

Supplied with:

- 1 protective nozzle
- 1 flat nozzle
- 1 reduction nozzle
- 1 reflective nozzle
- 1 scraper



### SOLDERING IRON 30W WITH STAND

OE 0811

TN

This soldering iron is ideal for a multitude of works. The high quality tip is suitable for lead-free soldering.

The work stand has two crocodile clips for holding electronic boards.  
Weight: 560g



Delivered with tin, tips and sponge



### PORTABLE GAS SOLDERING IRON

EG 0050

TN



**Specifications:**

- solder up to 500°C
- 4-position adjustment
- supplied with 4 tips
- after-use support





TN

## MINI TORCH WITH RETRACTABLE TUBING + GAS REFILL

EG 0541



**Contents:**

- EG0540: mini torch with retractable tubing
  - 1 Mini Gas torch
  - Assorted colored retractable tubing and sizes:
    - 1x15mmx500mm
    - 60x1.5mm
    - 35x2.5mm
    - 25x3mm
    - 20x5mm
    - 10x6mm
    - 10x10mm

- EG0047: gaz refill

EG 0540	MINI TORCH WITH RETRACTABLE TUBING
SA 0541	RANGE OF RETRACTABLE SLEEVES
EG 0047	GAS REFILL
SA 0540	MINI TORCH

NO WARRANTY

## WIRE BRUSH

EG 0056



Handy steel wire metallic brush ideal for a multitude of uses.

- carbon steel wire
- soft grip handle

NO WARRANTY

## WHITE WASHABLE MARKER FOR ALL SURFACES

EG 0021

Water based washable paint marker

**Specifications:**

- UV resistant
- for all surfaces: metal, plastic, wood, glass, stone, foil...
- transparent body so you can immediately see how much paint is left
- VOC less than 0.6% (Volatile Organic Compounds)
- complies with standard ASTM D436 (non toxic)



NO WARRANTY



MAGNETIC FLEXIBLE PICK UP TOOL Ø5mm L.525mm

OM 8088



TN



MAGNETIC FLEXIBLE PICK UP TOOL Ø5mm L.1070mm

OM 8086



★ TOP PRODUCT

TN

LONG FLEXIBLE MAGNETIC SHAFT

OM 8087

+ 2-in-1 product

This tools allows small objects to be retrieved and picked up in confined areas. The 4 curved claws ensure a correct grip, and the powerful magnet is ideal for metallic objects.

Specifications:

- total length: 700mm
- magnet Ø15mm
- flexible shaft and aluminum bracket

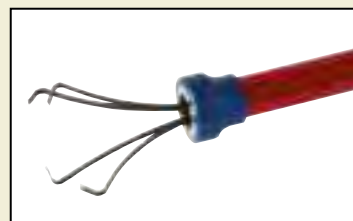

TELESCOPIC MAGNET 170mm-670mm

TN

OM 8071



TELESCOPIC MIRROR 228mm-715mm

TN

OM 8074





## RIVETING PLIERS

OM 0749BL



**Specifications:**

- handle sheathed with return spring
- supplied with 4 nozzles Ø2.4-3.2-4.0-4.8mm
- key for nozzle assembly
- length: 270mm

TN



## PRO PLIERS FOR RIVETS & LOCKNUTS

OM 0480

Suitable for:

- rivets Ø2.4-3.2-4-4.8-6.4mm
- locknuts Ø4-5-6-8-10mm



**NOTE**

Pneumatic solutions  
See p. 116



**Contents:**

- m4-M5-M6-M8-M10 pull spindles
- 3.2-4.0-4.8 et 6.4mm nozzles

SA 1489 REPAIR KIT FOR RIVETING PLIERS

Spare part of OM 0480

TN



## THREADED RIVET SET (150 PCS)

CO 0480

**Contents:**

- 25 crimp nuts M3x9mm
- 25 crimp nuts M4x11mm
- 25 crimp nuts M5x13mm
- 25 crimp nuts M6x15mm
- 25 crimp nuts M8x18mm
- 25 crimp nuts M10x21mm

SA 2481 THREADED RIVET M3x9mm (25 PCS)

SA 2482 THREADED RIVET M4x11mm (25 PCS)

SA 2483 THREADED RIVET M5x13mm (25 PCS)

SA 2484 THREADED RIVET M6x15mm (25 PCS)

SA 2485 THREADED RIVET M8x18mm (25 PCS)

SA 2486 THREADED RIVET M10x21mm (25 PCS)



TN





TN

### HOOK SET FOR JOINTS (4 PCS)

OM 9216

Special hooks for joints L.130mm

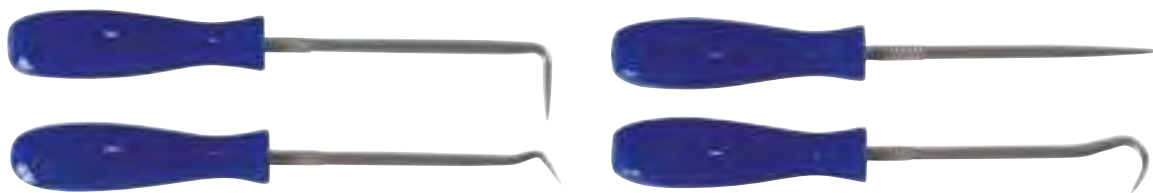

### LEVER SET WITH STRIKE DISK (4 PCS)

OM 0258

TN



**Contents:**

- SA0242: lever with strike disk L.200mm
- SA0243: lever with strike disk L.300mm
- SA0244: lever with strike disk L.450mm
- SA0246: lever with strike disk L.600mm



### NUT SPLITTER

OM 0623

TN

This set allows to quickly remove corroded, seized or damaged nuts.  
 The principle is simple: the nut is sheared to release the screw thread.  
 Practical and easy to use, this nut splitter set is a must-have in every workshop.



**Contents:**

- SA0624: nut splitter for nuts from 9 to 12mm
- SA0625: nut splitter for nuts from 12 to 16mm
- SA0626: nut splitter for nuts from 16 to 24mm
- SA0627: nut splitter for nuts from 22 à 27mm





419 PIECE O-RING JOINT SET

EG 0525

Suitable for: fuel, oil, acid.

- |                  |                   |                   |
|------------------|-------------------|-------------------|
| <b>Contents:</b> | 14pcs. 16x2.5mm   | 10pcs. 28x3.5mm   |
| 20pcs. 3x1.5mm   | 14pcs. 18x2.5mm   | 10pcs. 30x3.5mm   |
| 20pcs. 4.4x2mm   | 13pcs. 19x2.5mm   | 10pcs. 31x3.5mm   |
| 18pcs. 5x2mm     | 14pcs. 21x2.5mm   | 10pcs. 33x3.5mm   |
| 23pcs. 7x1.5mm   | 13pcs. 22x2.5mm   | 10pcs. 34.5x3.5mm |
| 23pcs. 10x1.5mm  | 10pcs. 18x3.5mm   | 10pcs. 36x3.5mm   |
| 23pcs. 13x1.5mm  | 10pcs. 20x3.5mm   | 10pcs. 38x3.5mm   |
| 14pcs. 10x2.5mm  | 10pcs. 22x3.5mm   | 10pcs. 41x3.5mm   |
| 13pcs. 11x2.5mm  | 10pcs. 23.5x3.5mm | 10pcs. 44x3.5mm   |
| 14pcs. 13x2.5mm  | 10pcs. 25x3.5mm   | 10pcs. 47x3.5mm   |
| 13pcs. 14x2.5mm  | 10pcs. 26.5x3.5mm | 10pcs. 50x3.5mm   |



NO WARRANTY

TN

E TYPE EXTERNAL CIRCLIP SET 1.5-22mm (300 PCS)

CO 0525

- |                  |            |
|------------------|------------|
| <b>Contents:</b> | • 10mm x50 |
| • 1.5mm x30      | • 12mm x40 |
| • 3mm x30        | • 15mm x20 |
| • 5mm x40        | • 19mm x20 |
| • 6mm x50        | • 22mm x20 |

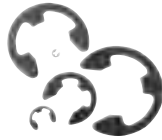

TN

3-32mm EXTERNAL CIRCLIP SET (300 PCS)

CO 0527

- |                  |            |
|------------------|------------|
| <b>Contents:</b> | • 14mm x15 |
| • 3mm x20        | • 16mm x20 |
| • 4mm x10        | • 19mm x25 |
| • 5mm x15        | • 20mm x15 |
| • 6mm x25        | • 22mm x20 |
| • 8 mm x15       | • 25mm x15 |
| • 9mm x20        | • 26mm x15 |
| • 11mm x15       | • 28mm x10 |
| • 12mm x15       | • 32mm x5  |
| • 13mm x25       |            |



3-32mm INTERNAL CIRCLIP SET (300 PCS)

CO 0526

- |                  |            |
|------------------|------------|
| <b>Contents:</b> | • 14mm x15 |
| • 3mm x20        | • 16mm x20 |
| • 4mm x10        | • 19mm x25 |
| • 5mm x15        | • 20mm x15 |
| • 6mm x25        | • 22mm x20 |
| • 8 mm x15       | • 25mm x15 |
| • 9mm x20        | • 26mm x15 |
| • 11mm x15       | • 28mm x10 |
| • 12mm x15       | • 32mm x5  |
| • 13mm x25       |            |



NO WARRANTY

LUBRICANT SILICONE UNIVERSAL SPRAY 500ml

CO 1030



**+** Anti corrosion  
Anti oxidation

Also available in box of 12

LUBRICANT TEFLON SPRAY 500ml

CO 1031



**+** Without residues of fat and silicone: dust does not stick.

Also available in box of 12

SUPER RELEASING GRAPHITE SPRAY 400ml

CO 1026



**+** Long-term protection

Also available in box of 12

BLACK STRUCTURAL GLUE 50ml

CO 1024



**+** Ideal for plastic repair

Also available in box of 48

MASTIC REPAIR BAR TO MODEL METAL 57g

CO 1046



**+** Can be drilled, tapped, threaded, filed, painted...

FLEXIBLE INSTANT GLUE 20g

CO 1032



**+** Rapid and instantaneous adhesion

Also available in box of 48

NO WARRANTY





# INDUCTION HEATERS

TN

## INDUCTION HEATER

OE 0800

Allows a room to be heated in a precise area, meaning that nuts, screws, bolts, bolted connections, hubs (even if rusted), lambda probes, ball bearings can be unblocked...It also allows stickers to be easily removed and stuck door rods to be disassembled or HGV wheel screws to be removed.

**+** Improved security  
Time gain



Command control

Coil lock

### Specifications:

- frequency: 25-60kHz
- automatic overheating shutdown
- short-circuit and open circuit security, overload alarm
- dimensions: 200x140x75mm

### Contents:

- deported induction central unit with 3m supply cable and 70cm connector (to improve accessibility)
- SA0819: rigid induction coil Ø19mm length 220mm
- SA0832: rigid induction coil Ø32mm length 220mm
- SA0818: flexible coil length 800mm
- SA0817: induction pad Ø50mm length 220mm
- shoulder strap
- plastic case with foam



SA 0816	RIGID INDUCTION COIL Ø23mm	Spare part of OE 0800/OE 0610
SA 0817	ROUND INDUCTION PAD Ø50mm	Spare part of OE 0800/OE 0610
SA 0818	FLEXIBLE INDUCTION COIL	Spare part of OE 0800/OE 0610
SA 0819	RIGID INDUCTION COIL Ø19mm	Spare part of OE 0800/OE 0610
SA 0832	RIGID INDUCTION COIL Ø32mm	Spare part of OE 0800/OE 0610
SA 0838	RIGID INDUCTION COIL Ø38mm	Spare part of OE 0800/OE 0610



## HGV INDUCTION HEATER

OE 0900

This tool allows to heat a part in a precise place, thus facilitating the unlocking of screws, nuts, bolts, rods, hubs (even rusty), lambda probes, ball bearings... It also makes it easy to remove stickers, remove glued door sticks or HGV wheel nuts.

**+** Increased security  
Saving time



It is a real alternative to the torch or flame torch: its induction system allows to heat precisely and without flame a metallic (conductive) part without risk of deterioration of the surrounding non-conductive parts (glass, plastic, paint...)  
In addition, the operator saves considerable time when using the tool.

**Contents:**

- remote induction central unit with 3m mains cable and 2m connecting cable (for accessibility)
- induction coil with side heating

**Specifications:**

- frequency: 18-60kHz
- power: 3.7kVA
- power regulator: 10-100%
- control screen and timer
- LED illumination of the work area
- water-cooled
- dimensions: 240x200x440mm
- weight: 11.5kg







## ELECTRONIC MEASURING TOOLS

### POLARITY/CONTINUITY TESTER 3 TO 48V

OE 0065BL

Voltage and battery tester for cars, HGVs and motorbikes. Positive/negative cables test.

TN

**B.LINE**  
BUDGET SOLUTION

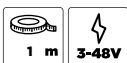

### UNIVERSAL NON INTRUSIVE TEST PROBE SET CAT. II

AC 5115

Suitable for all standard 4mm instrument sockets.

TN

**Contents:**

- pair of test leads with straight and 90° connectors max. 1000V, L.120cm
- pair of cable piercers for intrusive measures taking max. 30V
- pair of slim probes for inversed tests max. 24V



### CLAMP METER 1000A

OE 5020

**Specifications:**

- intensity test
- amperemeter test
- diode test
- continuity test
- data-hold function
- IEC 61010 CATII with overload protection
- 3 16mm digit backlit LCD screen
- automatic scales
- comes with battery and test lead
- aperture of the pliers: 55mm
- DC voltage: 600V±(0.5%+5)
- AC voltage: 600V±(1%+5)
- direct current: 200/1000A±(2.5%+5)
- alternating current: 200/1000A±(2.5%+5)
- resistance: 200 ohms±(1.2%+5)
- frequency: 2kHz±(2%+5)
- power supply: 9Vx1





CAT.I DIGITAL MULTIMETER

OE 3008BL



Specifications:

- DC voltage: 200mV-2000mV-20V-200V-500V
- AC voltage: 200V-500V
- DC current: 200uA-20mA-200mA
- resistance: 200ohm-2000ohm-20Kohm-200Kohm-2000Kohm
- battery: 6LR61 PP3
- dimensions: 126x70x24mm



DIGITAL MULTIMETER CAT. III

OE 3004



Specifications:

- DC voltage: 200mV-2V-20V-200V-300V
- AC voltage: 200mV-2V-20V-200V-300V
- DC current: 20mA-200mA-10A
- AC current: 20mA-200mA-10A
- resistance: 200ohm-2kohm-20kohm-200kohm-2Mohm-20Mohm
- diode test: approx. 2.8V
- temperature: 0-1000°C
- battery test: 1.5-9V-12V
- continuity: <30ohm
- light at the top



BLACK TOUCH POINT IP2X FOR VAT DEVICE

OE 3011

Accessory of OE 3010

IP2X measuring tip with 4 mm female banana coupling, black. Hard tip to scrape varnish, paint, oxidation. Safety 1000 V CAT IV



Standard: IEC 61010-031



RED TOUCH POINT IP2X FOR VAT DEVICE

OE 3012

Accessory of OE 3010

IP2X measuring tip with 4 mm female banana coupling, red. Hard tip to scrape varnish, paint, oxidation. Safety 1000 V CAT IV



Standard: IEC 61010-031





# TAPS & DIES

## DRILL SET HSS4241 (25 PCS)

TN

EG 0670BL



**Contents:**

- drills from 1.0 to 13.0mm, every 0.5mm



## DRILL SET HSS COBALT 5% (25PCS)

TN

EG 0680

HSS drills with 5% cobalt have a longer service life and are ideal for drilling hard metals such as stainless steel.



**Contents:**

- drills from 1.0 to 13.0mm, every 0.5mm
- material: Cobalt HSS 5%



## DRILL SET HSS4241 (170 PCS)

TN

EG 0671BL



**Contents:**

- 10 drills bits of 1mm
- 10 drills bits of 1,5mm
- 10 drills bits of 2mm
- 10 drills bits of 2,5mm
- 10 drills bits of 3mm
- 10 drills bits of 3,5mm
- 10 drills bits of 4mm
- 10 drills bits of 4,5mm
- 10 drills bits of 5mm
- 10 drills bits of 5,5mm
- 10 drills bits of 6mm
- 10 drills bits of 6,5mm
- 10 drills bits of 7mm
- 10 drills bits of 7,5mm
- 10 drills bits of 8mm
- 5 drills bits of 8,5mm
- 5 drills bits of 9mm
- 5 drills bits of 9,5mm
- 5 drills bits of 10mm



### NOTE

Discover the complete range of portable power tools p. 133



## DRILL SET HSS COBALT 5% (170 PCS)

TN

EG 0681

HSS drills with 5% cobalt have an increased life and can drill hard metals such as stainless steel.

**Contents:**

- 10 drills bits of 1mm
- 10 drills bits of 1,5mm
- 10 drills bits of 2mm
- 10 drills bits of 2,5mm
- 10 drills bits of 3mm
- 10 drills bits of 3,5mm
- 10 drills bits of 4mm
- 10 drills bits of 4,5mm
- 10 drills bits of 5mm
- 10 drills bits of 5,5mm
- 10 drills bits of 6mm
- 10 drills bits of 6,5mm
- 10 drills bits of 7mm
- 10 drills bits of 7,5mm
- 10 drills bits of 8mm
- 5 drills bits of 8,5mm
- 5 drills bits of 9mm
- 5 drills bits of 9,5mm
- 5 drills bits of 10mm

Material: Cobalt HSS 5%



## OIL CAN 500ml

TN

HU 0511



## 4-32mm HSS STEP DRILL

TN

EG 0432



Stepping: 2mm





DRILL-TAPS-DIES SET (37 PCS)

OM 9221

**Contents:**

- 8 dies: 3x0.5-3.5x0.6-4x0.7-5x0.8-6x1.0-8x1.25-10x1.50-12x1.75
- 8 taper taps
- 8 bottoming taps in sizes shown
- 8 HSS drills 2.5/2.9/3.3/4.2/5/6.8/8.5/10.3mm
- + accessories



TN

NO WARRANTY

★ TOP PRODUCT

TAP & DIE SET (52 PCS)

OM 9222

**Contents:**

- 7 dies: M3x0.5/M4x0.7/M5x0.8/M6x1.0/M8x1.25/M10x1.50/M12x1.75
- 5 UNF dies 1/4", 5/16", 3/8", 1/2"
- 2 BSP dies 1/8", 1/4"
- 14 taps sizes as indicated
- 13 HSS drills: 2.5-3.3-4.2-5-5.5-6.8-6.9-8.5-8.8-9-9-10-10.3-11.4-11.8mm
- 5 pigtail extractor N°1-2-3-4-5
- + accessories



TN

NO WARRANTY

TAP & DIE SET (75 PCS)

OM 9223

**Contents:**

- 18 dies: M2x0.25-M3x0.35-M3x0.5-M3.5x0.6-M4x0.5-M4x0.7-M4.5x0.75-M5x0.5-M5x0.8-M6x0.75-M6x1.0-M8x1.0- m8x1.25-M10x1.25-M10x1.5-M12x1.25-M12x1.75-BSP28 1/8"
- 18 taps coarse shank, dimensions see dies
- 18 taps fine shank, dimensions see dies
- 17 HSS drill bits: 1.7-2.5-2.6-2.9-3.3-3.5-3.8-4.2-4.5-5-5.3-6.8-7-8.5-8.8-10.3-10.7mm
- + accessories



TN

NO WARRANTY

5 CARBIDE ROTARY RASPS BOX

OM 0643



**Specifications:**

- right cut
- diamond gearing
- 6mm cylindrical shank
- material: carbide

NO WARRANTY

TN

SCREW EXTRACTOR SET + DRILLS (10PCS)

OM 0668



TN

NO WARRANTY





## DRILLING & THREADING

### 10 PCS M14x2.0 INSERT SET

OM 0458



Stainless steel inserts

TN

NO WARRANTY

### 10 PCS M14x125 INSERT SET

OM 0457



Stainless steel inserts.  
Special spark plug thread.

TN

NO WARRANTY

OM 0486 M5x0.8 INSERT SET

#### Contents:

- drill Ø5.2mm
- tap M5x0.8
- running tool insert
- 25 stainless steel inserts

OM 0487 M6x1.0 INSERTS SET

#### Contents:

- drill Ø6.3mm
- tap M6x1.0
- running tool insert
- 25 stainless steel inserts

OM 0488 M8x1.25 INSERT SET

#### Contents:

- drill Ø8.3mm
- tap M8x1.25
- running tool insert
- 25 stainless steel inserts

OM 0489 M10x1.50 INSERT SET

#### Contents:

- drill Ø10.4mm
- tap M10x1.5
- running tool insert
- 25 stainless steel inserts

OM 0490 M12x1.75 INSERT SET

#### Contents:

- drill Ø12.4mm
- tap M12x1.75
- running tool insert
- 25 stainless steel inserts



TN

NO WARRANTY

### M5-M12 INSERT SET

OM 0450

For repairing worn or damaged threading.  
Inserts in stainless steel, highly resistant to breaking, corrosion and temperature.  
Box made up of inserts from M5 to M12, helical drills, taps, assembly tools and tang breakers.



TN

OM 0452 25 PCS M5x0.8 INSERT SET

OM 0453 25 PCS M6x1 INSERT SET

OM 0454 25 PCS M8x1.25 INSERT SET

OM 0455 25 PCS M10x1.50 INSERT SET

OM 0456 10 PCS M12x1.75 INSERT SET

#### Contents:

- helical drills
- taps
- assembly tools
- tang breakers

NO WARRANTY



## METRICAL INNER/OUTER THREAD FILE 0.8-3.0

OM 9300

Allows the inner or outer thread to be measured in order to reform them by passing over the affected area.

Each side of thread has a different notch as follows:  
0.80-1.00-1.25-1.50-1.75-2.00-3.00  
Length: 230mm



TN

NO WARRANTY

## EXTERNAL RETHREADING TOOL Ø17-Ø38mm

OM 9309

A single tool to restore both right and left hand threads in inches or metric!



Reduced bulk



### Specifications:

- no calibration required
- automatically adjusts to any pitch/size
- automatically drives out the correct threads to repair damage
- 11/16"-1-1/2" 17-38mm
- pipe thread up to 3/8" - 1-1/8"
- 60° , ISO, UNC, UNF, NPT
- 55° , BSW, BSF, BSP

TN

2 WARRANTY

## TAP HOLDERS AND RATCHET THREADERS BOX

OM 9325



### Contents:

- 1 ratchet 3/8"
- 2 die-holders Øext: 9 to 25mm
- 2 tap holders M3 to M12

TN

2 WARRANTY



## FLOOR JACK (MOBILE SERVICE)



REF	OH 6302BL	OH 5304	OH 5311	OH 5309
Vehicle type				
Intensity of use				
Max. load	2T	2T	3T	1.25T
Height min.	135mm	85mm	192mm	85mm
Max. height	340mm	381mm	533mm	375mm
Lowering	braked	braked	braked	braked
Wheel	steel	steel	steel	aluminum/steel
Drive	offset	offset	offset	u-joint
Pump	single piston	single piston	single piston	dual piston
Weight (kg)	8.7	12.6	19	11.5
Repairability				
Extra flat		•		•
Budget	€	€	€	€€

## GARAGE JACK (WORKSHOP)



REF	OH 5306	OH 6303	OH 7014	OH 5355	OH 5360
Vehicle type					
Intensity of use					
Max. load	2.25T	3T	3T	5T	10T
Height min.	140mm	130mm	75mm	150mm	160mm
Max. height	490mm	465mm	510mm	560mm	560mm
Lowering	braked	braked	braked	braked	braked
Approach pedal		•	•	•	•
Wheel	steel	steel	PU	steel	steel
Drive	gable	cardan	cardan	mechanics	mechanics
Pump	single piston	dual piston	dual piston	single piston	single piston
Weight (kg)	29.5	30	30.5	87	129
Repairability					
Extra long				•	•
Extra flat			•		
Budget	€€	€€€	€€€	€€€€	€€€€

## AIR HYDRAULIC JACK



REF	OH 9021	OH 3015N	OH 9042N	OH 5030N	OH 9032N
Vehicle type					
Intensity of use					
Max. load	30T	30T	40T	50T	30T
Height min.	150mm	150mm	129mm	150mm	360mm
Max. height	289mm	289mm	276mm	300mm	627mm
Capacity per floor	30T/15T	30T/15T	40T/22T/10T	50T/30T/15T	30T
Lowering speed control	•	•	•	•	•
Transport	Carrying handle + folding handle				
Weight (kg)	24	38	36	56	87
Repairability					
Budget	€	€	€€	€€	€€€



# TROLLEY JACKS

## TROLLEY JACK 2T

OH 6302BL

**Specifications:**

- rotating soleplate
- robust chassis
- anti-overload system
- transportation handle
- min. H.: 135mm
- max. H.: 340mm
- handle length: 740mm
- dimensions: 447x196x135mm
- weight: 8.7kg

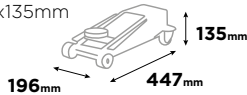

**B.LINE**  
BUDGET SOLUTION

2T

TN

## ★ TOP PRODUCT

## EXTRA FLAT TROLLEY JACK 2T 85mm

OH 5304

+ Extra low profile

**Specifications:**

- rotating saddle
- safety overload system
- h. min.: 85mm
- h. max.: 381mm
- dimensions: 560x212x145mm
- weight: 13kg

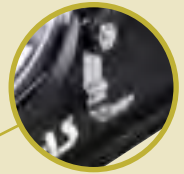
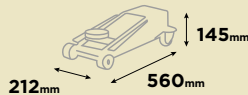

Handle storage

2T

TN

## HIGH ELEVATION TROLLEY JACK 3T

OH 5311

+ Telescopic head (+5cm)

**Specifications:**

- rotating saddle
- safety overload system
- h. min.: 192mm
- h. max.: 533mm
- dimensions: 635x255x192mm
- weight: 19kg

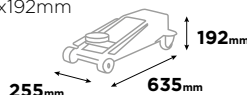

Handle storage

3T

TN





EXTRA FLAT ALUMINUM TROLLEY JACK 1.25T 85mm

OH 5309



**+** Ultra-light, ultra-flat,

Foam protection

Integrated buffer



Quick-release handle



Dual pump : fast rise



SA 5414	JOINTS REPAIR KIT
SA 5416	METAL SADDLE
SA 5417	COMPLETE RAM
SA 5415	CV JOINT
SA 5413	PAD
SA 5412	PAIR OF PIVOTING WHEELS Ø40x16mm
SA 5411	PAIR OF FIXED WHEELS Ø55x35mm

**Specifications:**

- rubber pad
- safety overload system
- twin pump design
- protective foam on the handles
- swivelling rear castors
- min. H.: 85mm
- max. H.: 375mm
- dimensions: 580x240x150mm
- weight: 11.5kg

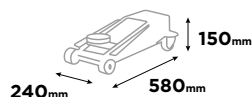

1.25T





### TROLLEY JACK 2.25T

OH 5306

TN



Sprockets



**Specifications:**

- robust chassis
- metered release system for a precise load control
- safety overload system
- swiveling steel saddle
- swivelling rear casters
- h. min.: 140mm
- h. max.: 490mm
- dimensions: 645x345x185mm
- weight: 31kg



↑ 490  
↓ 140 mm  
METAL  
31 KG

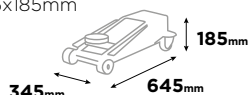

SA 5391	PAIR OF FIXED WHEELS Ø90x33mm
SA 5392	PAIR OF PIVOTING WHEELS Ø60x25mm
SA 5390	HANDLE RETURN SPRING
SA 5394	JOINTS REPAIR KIT
SA 5395	GEARWHEEL
SA 5396	COMPLETE RAM
SA 5367	METAL SADDLE

# 2.25T



### FOOT PEDAL TROLLEY JACK 3T

OH 6303

TN

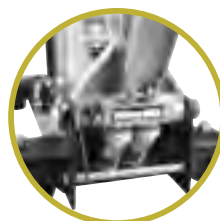

Double pump: fast pump-up



Reversible pad

**Specifications:**

- foot pedal
- anti-overload system
- iron wheels
- min. H.: 140mm
- max. H.: 490mm
- dimensions: 626x330x167mm
- weight: 29,5 kg



Max. T 3  
↑ 490  
↓ 140 mm  
QUICK LIFT  
METAL  
29.5 KG

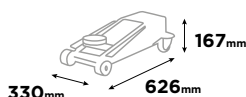

SA 6364	COMPLETE JACK
SA 6363	SWIVEL WHEEL
SA 6365	FIXED WHEEL
SA 6366	PEDAL RETURN SPRING
SA 6368	CARDAN
SA 6369	VERIN SPRING
SA 6362	CYLINDER GASKET KIT
SA 5367	METAL SADDLE

# 3T





TN

★ TOP PRODUCT

EXTRA FLAT TROLLEY JACK 3T 75mm

OH 7014



Foam protection on handle



Approach pedal

+ Extra low profile



Dual pump : fast rise



SA 7114	PAIR OF FRONT WHEELS
SA 7115	PAIR OF SWIVEL WHEELS
SA 7122	CV JOINT
SA 7116	SPRING CYLINDER
SA 7117	COMPLETE CYLINDER
SA 7118	FAST APPROACH PEDAL
SA 7119	SPRING RETURN HANDLE
SA 7120	STEEL BASE WITH SCREW AND PAD
SA 7121	RUBBER PAD
SA 7094	JACK HANDLE

Specifications:

- foot pedal
- control lowering system
- safety overload system
- swiveling rubber saddle
- fast lifting dual pump system
- foam protection on handle
- PU front and rear wheels
- h. min: 75mm
- h. max: 510mm
- dimensions: 740x350x230mm
- weight: 32.5kg

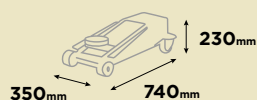

3T 10 WARRANTY





### LONG CHASSIS TROLLEY JACK 5T L.1505mm

OH 5355



Bearing-mounted swivel wheels



Approach pedal

**Specifications:**

- anti-overloading system
- controlled lowering system
- foot pedal
- ball bearing front/rear wheels ensure stability and manoeuvrability
- h. min.: 150mm
- h. max.: 560mm
- SA5355: pair of swiveling wheels
- SA5356: pair of front wheels
- dimensions: 1505x364x200mm
- weight: 87kg

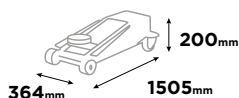

↑ 560  
↓ 150 mm  
METAL  
87

5T 10 WARRANTY

### DIMENSIONS

REF	A (mm)	E (mm)	F (mm)	G (mm)	H (mm)	J (mm)	L (mm)	K (mm)	Long. manche Handle lenght	Ø roues avant Front wheel Ø	Ø roues arrière Rear caster Ø
OH 5355	1505	31	31	200	290	364	245	130	1155mm	111mm	70mm
OH 5360	1637	24	24	250	333	490	245	150	1155mm	141mm	90mm

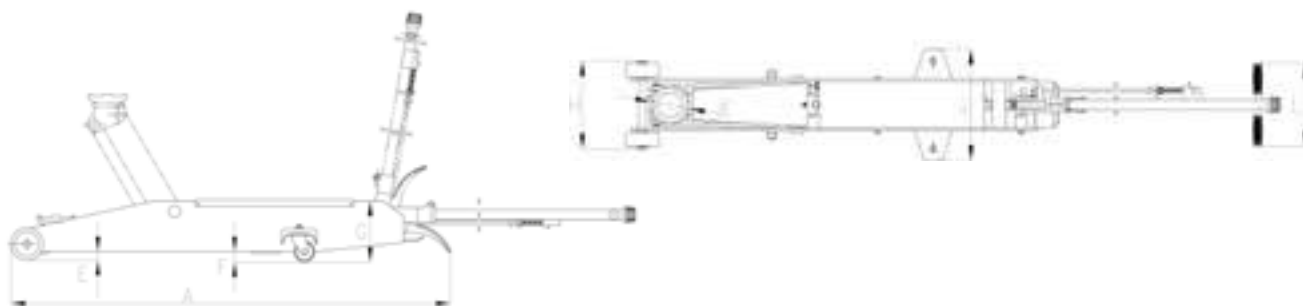

### LONG CHASSIS TROLLEY JACK 10T L.1637mm

OH 5360



Bearing-mounted swivel wheels



Approach pedal

**Specifications:**

- anti-overloading system
- controlled lowering system
- foot pedal
- ball bearing front/rear wheels ensure stability and manoeuvrability
- h. min.: 160mm
- h. max.: 560mm
- dimensions: 1637x490x250mm
- weight: 129kg

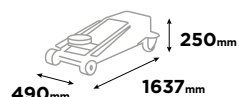

↑ 560  
↓ 160 mm  
METAL  
129

10T 10 WARRANTY



## AIR HYDRAULIC JACK 15-30T

OH 3015N

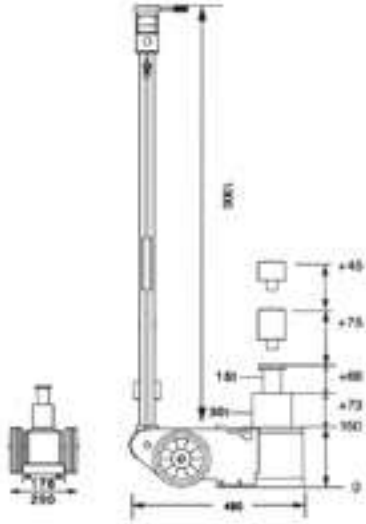

3-position handle:  
90-45-0° metal locking system



T-handle: easy positioning under the vehicle



Metal identification plate



### Specifications:

- provides quick and effortless lifts
- safety overload system
- equipped with a speed control descent system for enhanced security
- 2 stages: 30T/15T
- long T-handle allows you easily position your jack under the vehicle
- 3 positions: 90-45-0° with metal locking system
- tempered piston for high resistance
- extensions: 45-75mm
- air pressure: 9-12bar
- weight: 38kg

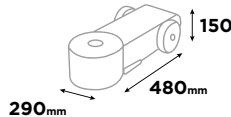

30T **2** WARRANTY

## FOLDABLE AIR HYDRAULIC JACK 15-30T

OH 9021

Applications: Trucks, trailers, buses

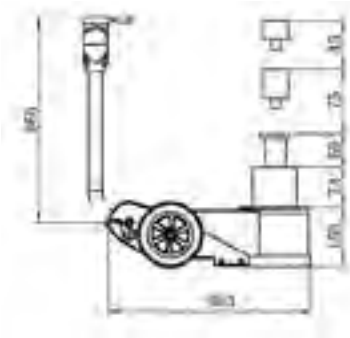

Approach pedal



Carrying handle



Metal identification plate

### Specifications:

- carrying handle
- provides quick and effortless lifts
- safety overload system
- 2 stages: 30T/15T
- equipped with a speed control descent system for enhanced security
- handle: 2 sectionable parts
- foldable handle which becomes a transportation grip
- separate controls for utilization with or without the 2nd part of the handle
- angular cutting of the chassis facilitates handling
- rubber wheels
- min. height: without extension 150mm/with extensions 270mm
- max. height: without extension 289mm/with extensions 409mm

- length: 503mm
- width: 280mm
- extensions: Ø67mm L.45-75mm, ergot Ø25mm
- air pressure: 9-12bar
- weight: 30,2kg

**+** Special assistance Ultra compact

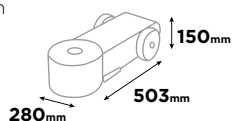

30T **2** WARRANTY



★ TOP PRODUCT

AIR HYDRAULIC JACK 10-22-40T

OH 9042N

**Applications:** Trucks, trailers, buses, agricultural machinery, civil engineering machinery.



+ Low profile

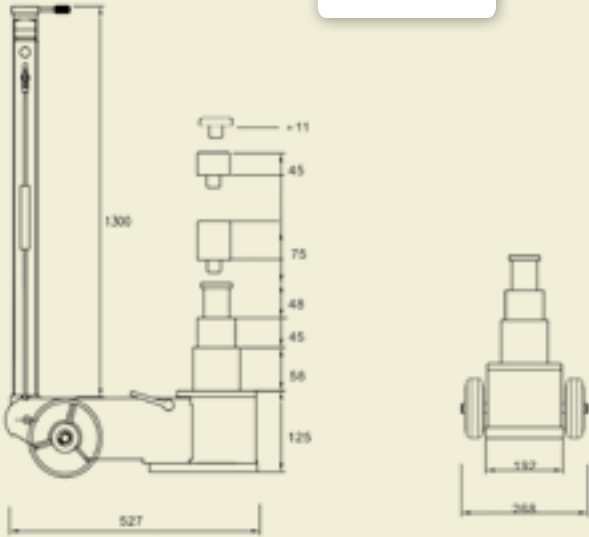

3-position handle: 90-45-0° metal locking system



T-handle: easy positioning under the vehicle



Metal identification plate

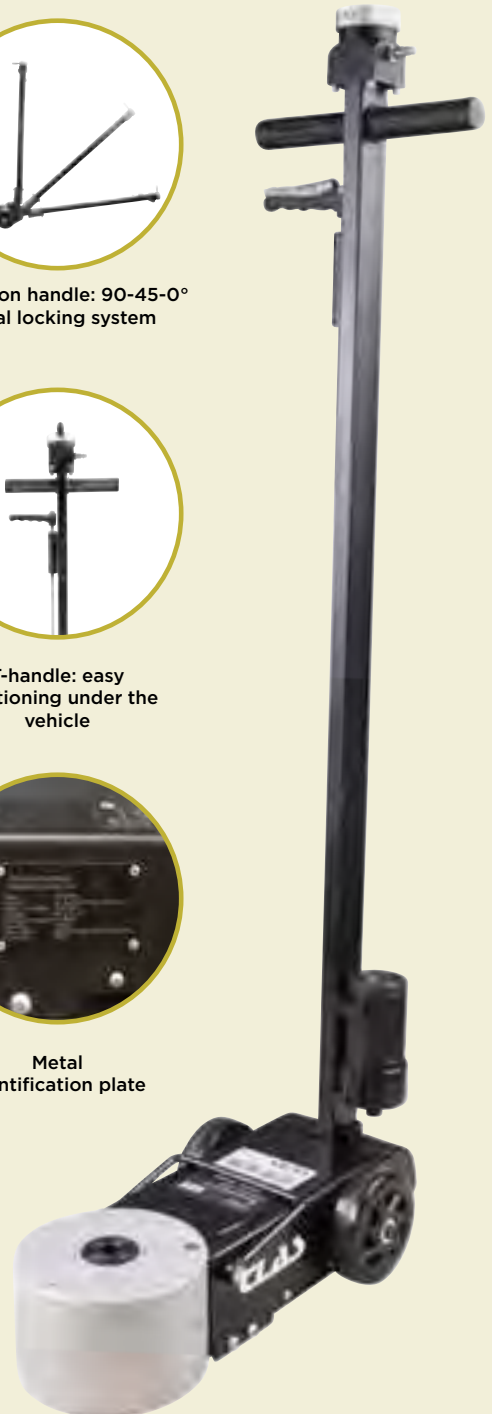

**Specifications:**

- provides quick and effortless lifts
- safety overload system
- 3 stages: 40-22-10T
- equipped with a speed control descent system for enhanced security
- long T-handle allows you easily position your jack under the vehicle
- 3 positions: 90-45-0° with metal locking system
- tempered piston for high resistance
- h. min.: without extension 125mm/with extensions 256mm
- h. max.: without extension 276mm/with extensions 407mm
- length: 527mm
- width: 268mm
- extensions: 11-45-75mm
- air pressure: 9-12bar
- weight: 38,4kg

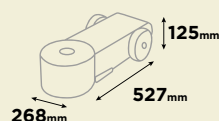

407	125 mm	GUM	9-12 bar	36 kg
10T	22T			
40T				

40T







# PNEUMATIC JACKS

## PNEUMATIC FLOOR JACK 2T-2 STAGES

TN

OP 0209

New internal structure to increase stability, internal telescopic guide.



**+** Fast and effortless lift

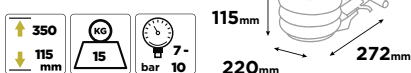

2T **2** WARRANTY

## PNEUMATIC FLOOR JACK 2T-3 STAGES

TN

OP 0309

New internal structure to increase stability, internal telescopic guide.

**+** Fast and effortless lift

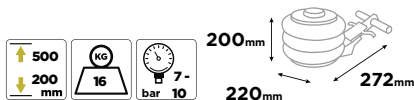

2T **2** WARRANTY

## EXTENSION L.60mm

TN

SA 9131

Accessory of OP 0209/OP 0309



**Specifications:**  
• Ø pin: 25mm

**2** WARRANTY

## EXTENSION L.80mm

TN

SA 9132

Accessory of OP 0209/OP 0309



**Specifications:**  
• Ø pin: 20mm

**2** WARRANTY





## BOTTLE JACKS

TN



Robust & airtight  
thanks to the welded  
base



REF	DESIGNATION	Min. height (mm)	Max. height (mm)	Weights	Base	Max. load (T)	Transport handle	Adjustable sole
OH 4502	BOTTLE JACK 2T	181	345	2,5 kg	99x93mm	2	No	0-48
OH 4504	BOTTLE JACK 4T	193	373	3 kg	110x103mm	4	No	0-60
OH 4506	BOTTLE JACK 6T	210	415	4 kg	122x115mm	6	No	0-70
OH 4512	BOTTLE JACK 12T	230	440	6,5 kg	140x126mm	12	No	0-60
OH 4520	BOTTLE JACK 20T	242	452	9,3 kg	159x143mm	20	No	0-60
OH 4530	BOTTLE JACK 30T	275	440	12,2 kg	169x153mm	30	Yes	
OH 4550	BOTTLE JACK 50T	265	425	25 kg	210x176mm	50	Yes	

2-50T

2  
WARRANTY



# JACK STANDS

TN



Load stabilization



Safety pin

REF	DESIGNATION	Min. height	Max. height	Weights	Max. load (T)
OM 3002BL	PAIR OF 2T JACK STANDS WITH SECURITY PIN	268mm	418mm	4,8 kg	2
★ OM 3030	PAIR OF 3T JACK STANDS WITH SECURITY PINS	276mm	420mm	6,4 kg	3
OM 3060	PAIR OF 6T JACK STANDS WITH SECURITY PINS	388mm	588mm	14 kg	6



OM 3030 JACK STAND RUBBER PAD

EG 1157

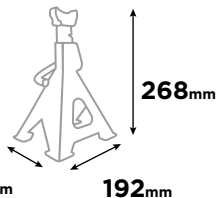

OM 3002BL

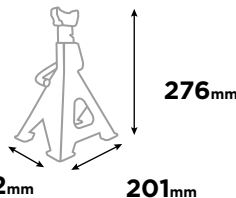

OM 3030

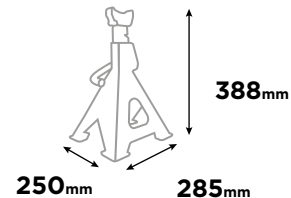

OM 3060

# 2-6T



## PAIR OF 10T JACK STANDS

OM 3100

TN

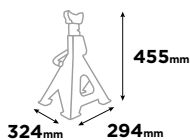

# 10T





TELESCOPIC PIT JACK

750 KG

OH 0280

TN

NEW



Specifications:

- foot-operated with precision adjustment
- wide base for greater stability
- quick adjustment
- wide handle for easy load support

Max. Kg 750	↑ 2060 ↓ 1390 mm	KG 15
----------------	---------------------	----------

750kg

2	WARRANTY
---	----------

PAIR TALL JACK STANDS 2T

OM 2013

TN

Specifications:

- h. min.: 1200mm
- h. max.: 1710mm
- weight: 35kg

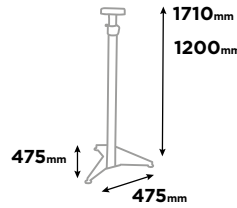

Max. T 2	↑ 1710 ↓ 1200 mm	KG 35
-------------	---------------------	----------

2T

2	WARRANTY
---	----------

PAIR OF MOBILE 20T PIN JACKS

OM 0694

TN

NEW

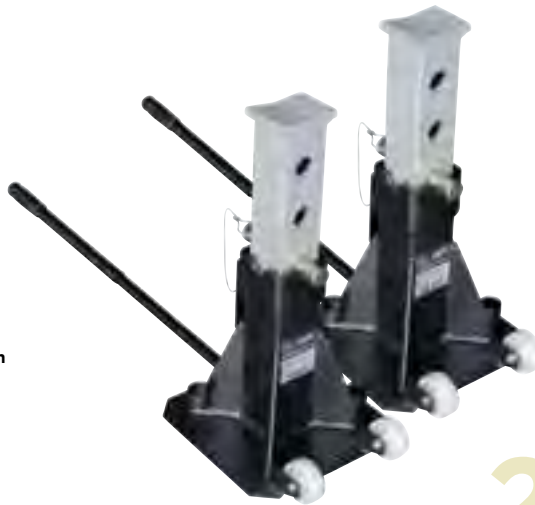

Specifications:

- min.h: 360mm
- max. height: 510mm
- base plate: 280x330 mm
- weight: 30.6kg

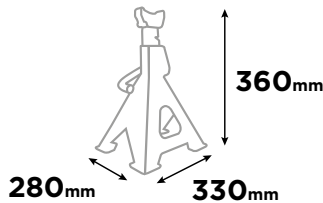

Max. T 20	↑ 510 ↓ 360 mm	KG 32
--------------	-------------------	----------

20T

2	WARRANTY
---	----------

JACK STANDS WITH SCREW 20T (x2)

OM 3021

TN

↑ 600 ↓ 410 mm	KG 56
-------------------	----------

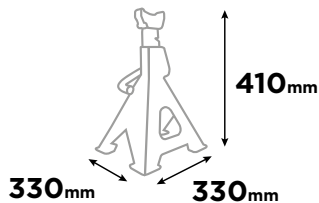

20T JACK STANDS WITH SCREW HIGH ELEVATION

OM 3023

↑ 1190 ↓ 665 mm	KG 76
--------------------	----------

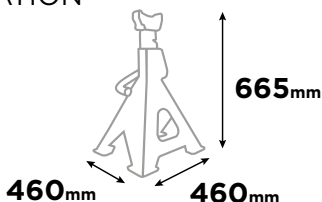

20T

2	WARRANTY
---	----------



# PIT JACKS

## PIT JACK 300kg

OH 0273

TN

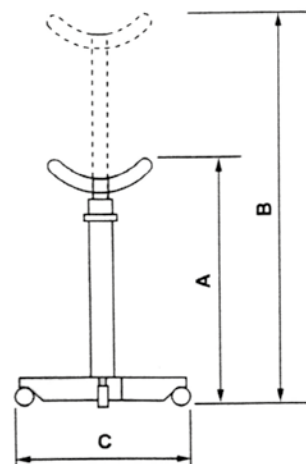

REF	Capacité Capacity	A (mm)	B (mm)	C (mm)	Poids Weight
OH 0273	300kg	1120	1890	800	23kg

**Specifications:**

- foot control
- chromed rod diameter 28mm
- overload safety
- deadman lowering control
- 4 swiveling wheels

<b>Max. Kg</b> 300	<b>↑ 1890</b> <b>↓ 1120</b> mm	<b>KG</b> 23
-----------------------	--------------------------------------	-----------------

# 300kg



### ★ TOP PRODUCT

TN

## PIT JACK 600kg

OH 0286



**+** Dead man's descent

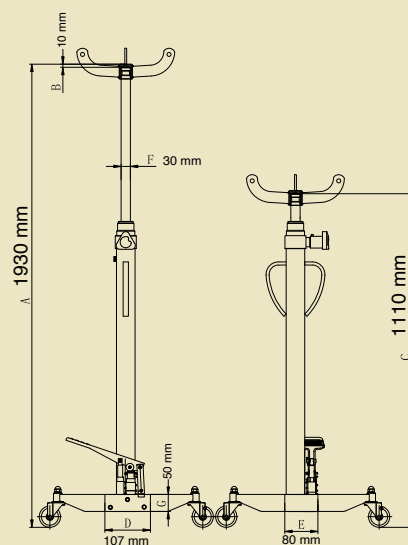

**Specifications:**

- foot-operated
- chrome-plated piston, diameter 30 for cylinder
- overload protection
- lowering control: deadman type
- 4 swivel wheels

<b>Max. Kg</b> 600	<b>↑ 1936</b> <b>↓ 1125</b> mm	<b>KG</b> 31
-----------------------	--------------------------------------	-----------------

# 600kg





PIT JACK 1T

OH 0285

TN

NEW



REF	A (mm)	B (mm)	C (mm)	D (mm)
OH 0285	888	1888	490	510



Specifications:

- foot-operated
- chrome-plated piston, diameter 30 for cylinder and 35mm for head
- overload protection
- lowering control: deadman type
- 4 swivel wheels

Max. T 1  
 ↑ 1940  
 ↓ 940 mm  
 KG 68

1T 2 WARRANTY

PIT JACK 600kg + SWIVEL HEAD

OH 0267

TN



Contents:

- OH0266: pit jack 300Kg
- OH0250: swivel head jacks 600Kg

600KG 2 WARRANTY

1T PIT JACK + GEARBOX SUPPORT

OH 0268

TN



Contents:

- OH0285: pit jack 1T
- OH0210: gearbox support

1T 2 WARRANTY





### SWIVEL HEAD JACKS 600kg

OH 0250

Accessory of OH 0286/OH 0285



**Specifications:**

- dimensions: 490x440x300mm
- tray : 360x270mm
- Tilt angle: Right:  $\geq 10^\circ$
- Tilt angle: Left:  $\geq 20^\circ$
- Tilt angle: Front:  $\geq 24^\circ$
- Tilt angle: Rear:  $\geq 19^\circ$
- Connection:  $\varnothing 30\text{mm}$
- chain length: 934mm
- weight: 21kg



600KG

### GEARBOX SUPPORT

OH 0210

Accessory of OH 0285/OH 0286



**Specifications:**

- maximum load capacity: 150kg
- length/width: 490mm/460mm
- forward/backward tilt:  $\pm 35$
- tilt left/right:  $\pm 5$
- weight: 12kg

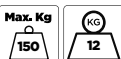



# WORKSHOP CRANES

## 1T FOLDABLE CRANE

OH 0336BL



**Specifications:**

- lifting capacity: 0-2060mm
- 4 positions arm: 1000-750-500-250kg
- height feet: 185mm
- 6 rotating wheels

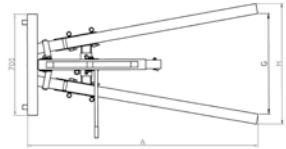
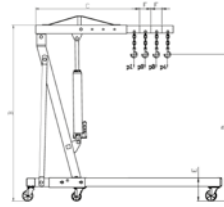

REF	Capacité Capacity	A (mm)	B (mm)	D (mm)	E (mm)	F (mm)	G (mm)	H (mm)
OH 0336BL	1T	1608	1435	420-1960	180	92	760	834

REF	P1 (kg)	P2 (kg)	P3 (kg)	P4 (kg)
OH 0336BL	1000	750	500	250

1T **2** WARRANTY

★ **TOP PRODUCT**

## 1T LOW PROFILE FOLDABLE CRANE

OH 0335

+ **Extra flat**

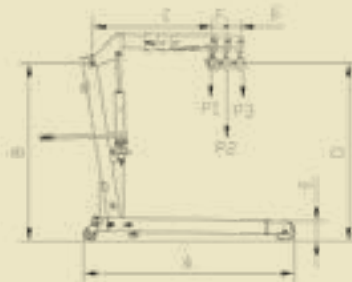

REF	Capacité Capacity	A (mm)	B (mm)	C (mm)	D1 (mm)	D2 (mm)	D3 (mm)
OH 0335	1T	1380	1600	1085	245-2330	100-2415	0-2500

REF	E (mm)	F (mm)	G (mm)	H (mm)	P1 (kg)	P2 (kg)	P3 (kg)
OH 0335	85	100	865	970	1000	750	500

**Specifications:**

- double acting pump
- 360° rotating pump
- deadman lowering control
- 3 positions arm: 1000-800-700kg
- low profile: 85mm
- nylon wheels
- weight: 71kg



1T **2** WARRANTY

**MOBILE CRANE 1T**

OH 1001

**Specifications:**

- 4-position arm: 1000-900-800-700kg
- double-acting pump
- weight: 92kg

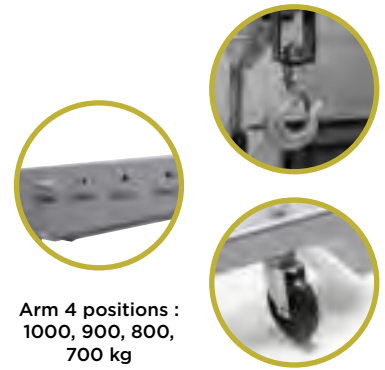
+ **European pallet format**Arm 4 positions :  
1000, 900, 800,  
700 kg**1T** **2** WARRANTY**DIMENSIONS**

REF	Capacité Capacity	A (mm)	B (mm)	C (mm)	D (mm)	E (mm)	F (mm)	G (mm)	H (mm)	P1 (kg)	P2 (kg)	P3 (kg)	P4 (kg)	Poids Weight
OH 1001	1T	1392	1570	1060	1150	120	100	835	963	1000	900	800	700	103 kg
OH 0338	2T	1977	1977	1290	0-2705	205	150	994	1158	2000	1700	1500	-	147 kg

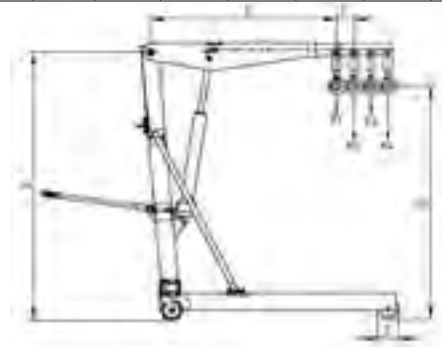
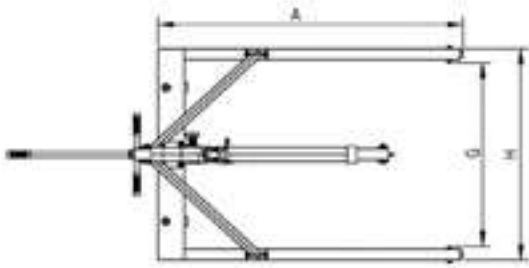
**1.5T CHARGE BALANCER FOR HEV BATTERIES**

OH 0260

**NEW**

This tool is an indispensable aid for moving and handling electric vehicle batteries. Its four straps ensure load stability by distributing the weight.

**Contents:**

- 1 main bar
- 2 crossbars
- 4 straps with eyebolts at each end
- 1 top hook for lifting

**1.5T** **2** WARRANTY**LOAD BALANCER 680kg**

OH 0238

**Specifications:**

- length: 400mm
- usable stroke: 350mm
- height: 50mm
- thickness: 12mm
- worm Ø: 15.8mm
- weight: 5.6kg

**680kg** **2** WARRANTY**DRUM GRIP 350kg**

OH 0009

**Specifications:**

- for plastic and metal drums up to 350kg
- max. opening 580mm

**350kg** **2** WARRANTY





## 2T FOLDABLE CRANE

OH 0338

3-position arm: 2000-1700-1500kg  
Max. load lift: 2550mm

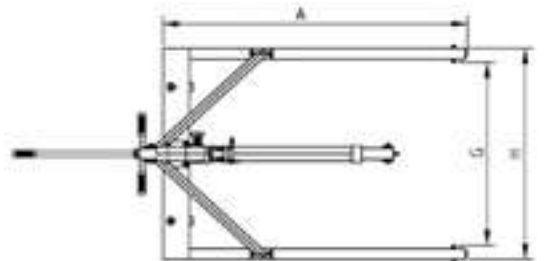
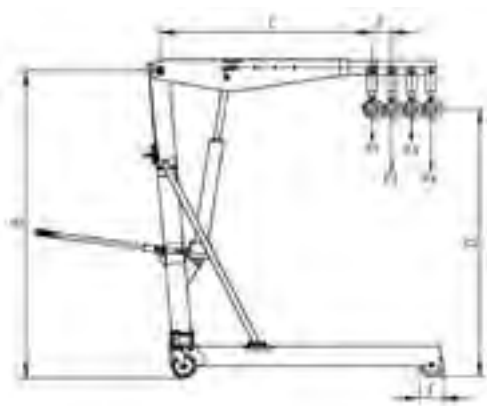

REF	Capacité Capacity	A (mm)	B (mm)	C (mm)	D (mm)	E (mm)	F (mm)	G (mm)	H (mm)	Poids Weight
OH 0338	2T	1977	1977	1290	0-2705	205	150	994	1158	-

**Specifications:**

- double-acting pump
- deadman descent
- 360° rotating pump
- 3-position arm: 2000-1700-1500kg
- max load lift: 255cm
- net weight: 149kg
- nylon wheels

Max. T 2	2550 175 mm	1.5T 1.7T 2T	NYLON	149 kg
-------------	----------------	--------------------	-------	--------

**2T** 2 WARRANTY





# LIFTING TABLES

REF	OH 1300	OH 1201	OH 1500
Minimum/maximum tray length	1010mm	1380/1580mm	1440mm/1600mm
Dimensions	575x1140x460	710x790x1580mm	580x800x1850mm
Min/max height	440/1575mm	710/2090mm	580/1800mm
Rise time	Depends on the load supported	50 sec	70 to 110 sec depending on load
Lowering time		30 sec	
Wheels	2 braked swivel wheels 150 mm 2 fixed wheels 150 mm	4 braked swivel wheels 130 mm	2 fixed and 2 swivel
Capacity	500 kg	1200kg	1500kg
Budget	€	€€	€€€
Energy	MANUAL	HYDROPNEUMATIC	HYDROPNEUMATIC
Weights	160kg	385kg	430kg
Descent safety	cable	cable	pneumatic

## 500kg HYDRAULIC LIFT TABLE

OH 1300

Ideal for handling parts (boxes, engines, axles, batteries...).



### NOTE

Pads and shims see p.26



2 fixed wheels and 2 swivel wheels with protective covers and brakes



Hydraulic lift control via foot pedal



L (mm)	W (mm)	D (mm)	H (mm)	H1 (mm)
1010	520	150	440	1575

### Specifications:

- pedal hydraulic lift command
- dead man-type descent command
- tray dimensions 1010x520mm
- 2 fixed wheels and 2 swiveling wheels with protective casing and brakes
- h. min.: 440mm
- h. max.: 1575mm
- weight: 152kg

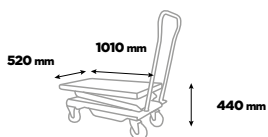

# 500KG





## LIFTING TABLE 1200kg FOR EV BATTERY AND HEAVY ORGANS

TE

OH 1201

This table is specially designed for the removal and re-installation of heavy components with a maximum load of 1T (electric vehicle battery and/or drive train). Versatile, it will be able to adapt to all your needs thanks to its many adjustments and its optional supports on request.



### NOTE

Technical information on lifting tables p.460

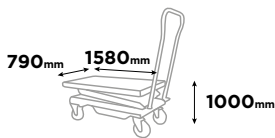

1.2T



## LIFTING TABLE 1500kg FOR EV BATTERY AND HEAVY ORGANS

TE

OH 1500



### Specifications:

- h. min.: 580mm
- h. max.: 1800mm
- max. height on safety catches: 1740mm
- rise time (depending on the load) : 70-110 sec (example: 73 seconds with a load of 457 kg)
- lowering time (depending on the load): +- 30 sec (example: 34 seconds with a load of 457 kg)
- platform length: 1400-1600mm
- platform width: 800mm
- overall length of telescopic frame: 1650mm to 1850mm
- equipped with two wheels made of aluminium and polyurethane: 2 fixed and 2 swivel with brake
- PU wheels
- max hydraulic pressure : 190bar
- pneumatic supply : 6-8bar
- weight : 430kg

**+** High load 1500Kg  
High precision of settings



1.5T



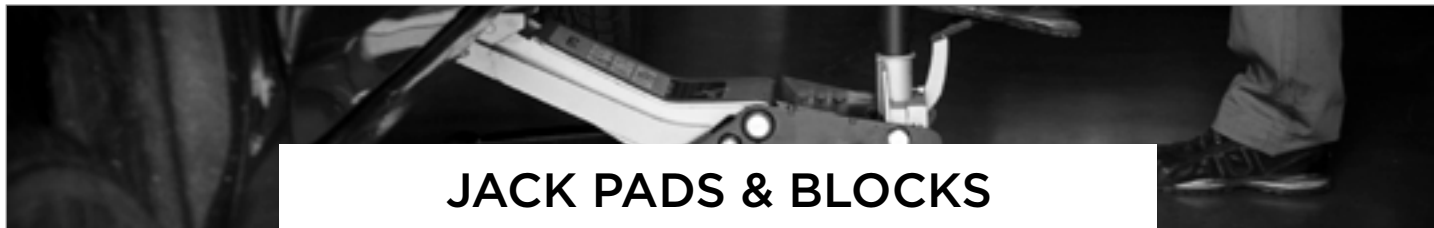

# JACK PADS & BLOCKS

Hardness 85° SHORE A





**Only sold per 4**

Detailed drawings and

dimensions on **clas.com**

	DESIGNATION	REF
	RECTANGULAR RUBBER PAD 160x120x30mm	<b>EG 1137</b>

**Rubber SBR 80° SHORE A****Only sold per 4**

	DESIGNATION	REF	Ø interior	Ø exterior	Compatibility
	ROUND RUBBER PAD Ø120x26mm	EG 1139	111 mm	120 mm	Suitable for Ravaglioli
	ROUND RUBBER PAD Ø124x26mm	EG 1141	108 mm	124 mm	Suitable for ATH, Ravaglioli, Werther
	ROUND RUBBER PAD Ø140x27mm	EG 1145	133 mm	140 mm	Suitable for OMCN
	REINFORCED ROUND RUBBER PAD (METALLIC PLATE) Ø125x24mm	EG 1147	120 mm	125 mm	Suitable with Nussbaum, AMI
	ROUND RUBBER PAD Ø130x10mm	EG 1148	125 mm	130 mm	Suitable for Ravaglioli, Siro, Space

**Sold individually**

	DESIGNATION	REF
	PAD FIAT 500E/500X/JEEP RENEGADE Ø100 X H.55	<b>EG 1154</b>
	UNIVERSAL REVERSIBLE RUBBER PAD JACK	<b>EG 1155</b>
	JACK RUBBER PAD BMW/MINI/OPEL	<b>EG 1156</b>
	OM 3030 JACK STAND RUBBER PAD	<b>EG 1157</b>



## PRESS SHOP

## HYDRAULIC PRESS 20T

OH 0921

**Specifications:**

- 1 speed hydraulic pump
- chrome piston with adjusting screw
- polycarbonate protection to protect the operator from splinters
- table height adjustable 12 positions
- winch-assisted up and down movement of the table
- 2 oversized pins to hold the table in place
- 159x88x40mm sliding drip tray
- large manometer
- reversible V-shaped support block, including punch kit and protective polycarbonate



Polycarbonate operator protection included on all models

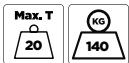

**+** Winch-assisted table

**NOTE**

Discover our range "Bearing" p.333



★ **DUAL-CONTROL HYDRAULIC PRESS 30T SLIDING CYLINDER**

OH 0931

**Specifications:**

- hydraulic pump
- manual override or hydropneumatic pedal
- chrome piston with adjusting screw
- sliding cylinder jack with handle and rating scale
- polycarbonate protection to protect the operator from splinters
- table height adjustable 12 positions
- winch-assisted up and down movement of the table
- 2 oversized pins to hold the table in place
- 226x136x55mm sliding drip tray
- large manometer
- reversible V-shaped support block, including punch kit and protective polycarbonate

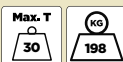

**DUAL-CONTROL HYDRAULIC PRESS 50T SLIDING CYLINDER**

OH 0951

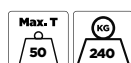

**20-50T**



TN

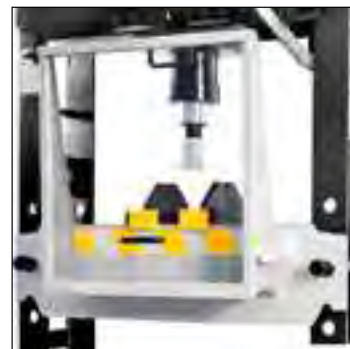

Protective polycarbonate screen to shield the operator

### HYDROPNEUMATIC PRESS 100T

OH 0910

**Specifications:**

- hydraulic pump
- manual control or hydropneumatic pedal (dual pedal up and down)
- chrome plated piston with adjustment screw
- sliding cylinder with handle and positioning scale
- polycarbonate screen protection (5,5 cm) to protect the operator against possible splinters
- table height adjustable in 12 positions
- table raising/lowering assisted by winch
- table holding by 2 oversized pins
- large pressure gauge
- reversible V-shaped support block and plexiglass set included.



# 100T



TN

### PRESS ACCESSORIES

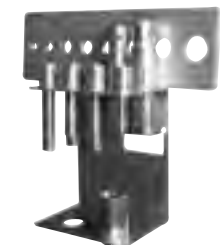

REF	LIBELLE	Compatibility
OH 0821	20T PUNCHER TOOLS	Spare part of OH 0820
OH 0831	30T PUNCHER TOOLS	Spare part of OH 0830/OH 0430
OH 0851	50T PUNCHER TOOLS	Spare part of OH 0850
OH 0810	100T PUNCHER TOOLS	Accessory of OH 0910/OH 0921/OH 0931/OH 0951



### BEARING FORK SEAL INSTALLATION/EXTRACTION KIT

OM 3419

**Contents:**

- 50 kits Ø18 to Ø74mm
- 1 cup support: 18mm
- 1 extender: 220mm



TN